

CHAPTER 31
SIGNALIZED INTERSECTIONS: SUPPLEMENTAL

CONTENTS

1. INTRODUCTION 31-1

2. CAPACITY AND PHASE DURATION 31-2

 Actuated Phase Duration 31-2

 Lane Group Flow Rate on Multiple-Lane Approaches 31-22

 Pretimed Phase Duration 31-30

 Pedestrian and Bicycle Adjustment Factors 31-34

 Work Zone Presence Adjustment Factor 31-40

3. QUEUE ACCUMULATION POLYGON 31-42

 Concepts 31-42

 General QAP Construction Procedure 31-43

 QAP Construction Procedure for Selected Lane Groups 31-45

4. QUEUE STORAGE RATIO 31-63

 Concepts 31-63

 Procedure for Estimating Back of Queue for Selected Lane Groups 31-70

5. PLANNING-LEVEL ANALYSIS APPLICATION 31-78

 Overview of the Application 31-78

 Required Data and Sources 31-80

 Methodology 31-80

 Worksheets 31-94

6. FIELD MEASUREMENT TECHNIQUES 31-99

 Field Measurement of Intersection Control Delay 31-99

 Field Measurement of Saturation Flow Rate 31-105

7. COMPUTATIONAL ENGINE DOCUMENTATION 31-111

 Flowcharts 31-111

 Linkage Lists 31-113

8. USE OF ALTERNATIVE TOOLS 31-119

 Effect of Storage Bay Overflow 31-119

 Effect of Right-Turn-on-Red Operation 31-121

Effect of Short Through Lanes 31-124

Effect of Closely Spaced Intersections 31-125

9. EXAMPLE PROBLEMS..... 31-127

 Example Problem 1: Motorized Vehicle LOS 31-127

 Example Problem 2: Pedestrian LOS 31-135

 Example Problem 3: Bicycle LOS..... 31-141

10. REFERENCES..... 31-144



LIST OF EXHIBITS

Exhibit 31-1 Time Elements Influencing Actuated Phase Duration 31-3

Exhibit 31-2 Detection Design and Maximum Allowable Headway 31-8

Exhibit 31-3 Force-Off Points, Yield Point, and Phase Splits 31-14

Exhibit 31-4 Example Equivalent Maximum Green for Fixed Force Mode 31-16

Exhibit 31-5 Probability of a Lane Change 31-24

Exhibit 31-6 Input Variables for Lane Group Flow Rate Procedure 31-25

Exhibit 31-7 Example Intersection 31-32

Exhibit 31-8 Conflict Zone Locations 31-35

Exhibit 31-9 Work Zone on an Intersection Approach 31-40

Exhibit 31-10 Geometric Design Input Data Requirements for Work
Zones 31-40

Exhibit 31-11 Queue Accumulation Polygon for Protected Movements 31-43

Exhibit 31-12 Unblocked Permitted Green Time 31-46

Exhibit 31-13 QAP for Permitted Left-Turn Operation in an Exclusive
Lane 31-56

Exhibit 31-14 QAP for Permitted Left-Turn Operation in a Shared Lane 31-56

Exhibit 31-15 QAP for Leading, Protected-Permitted Left-Turn Operation
in an Exclusive Lane 31-56

Exhibit 31-16 QAP for Lagging, Protected-Permitted Left-Turn Operation
in an Exclusive Lane 31-57

Exhibit 31-17 QAP for Leading, Protected-Permitted Left-Turn Operation
in a Shared Lane 31-57

Exhibit 31-18 QAP for Lagging, Protected-Permitted Left-Turn Operation
in a Shared Lane 31-57

Exhibit 31-19 Polygon for Uniform Delay Calculation 31-59

Exhibit 31-20 Time–Space Diagram of Vehicle Trajectory on an
Intersection Approach 31-64

Exhibit 31-21 Cumulative Arrivals and Departures During an
Oversaturated Analysis Period 31-65

Exhibit 31-22 Third-Term Back-of-Queue Size with Increasing Queue 31-66

Exhibit 31-23 Third-Term Back-of-Queue Size with Decreasing Queue 31-66

Exhibit 31-24 Third-Term Back-of-Queue Size with Queue Clearing 31-66

Exhibit 31-25 Arrival–Departure Polygon 31-69

Exhibit 31-26 ADP for Permitted Left-Turn Operation in an Exclusive
Lane 31-71

Exhibit 31-27 ADP for Permitted Left-Turn Operation in a Shared Lane 31-72

Exhibit 31-28 ADP for Leading, Protected-Permitted Left-Turn Operation
in an Exclusive Lane 31-72

Exhibit 31-29 ADP for Lagging, Protected-Permitted Left-Turn Operation
in an Exclusive Lane 31-72

Exhibit 31-30 ADP for Leading, Protected-Permitted Left-Turn Operation
in a Shared Lane 31-73

Exhibit 31-31 ADP for Lagging, Protected-Permitted Left-Turn Operation
in a Shared Lane 31-73

Exhibit 31-32 Required Input Data for the Planning-Level Analysis
Application 31-80

Exhibit 31-33 Planning-Level Analysis: Equivalency Factor for Left Turns..... 31-83

Exhibit 31-34 Planning-Level Analysis: Equivalency Factor for Right
Turns..... 31-83

Exhibit 31-35 Planning-Level Analysis: Equivalency Factor for Parking
Activity 31-83

Exhibit 31-36 Planning-Level Analysis: Equivalency Factor for Lane
Utilization 31-84

Exhibit 31-37 Planning-Level Analysis: Intersection Volume-to-Capacity
Ratio Assessment Levels..... 31-90

Exhibit 31-38 Planning-Level Analysis: Progression Adjustment Factor 31-92

Exhibit 31-39 Planning-Level Analysis: Input Worksheet 31-95

Exhibit 31-40 Planning-Level Analysis: Left-Turn Treatment Worksheet..... 31-96

Exhibit 31-41 Planning Level Analysis: Intersection Sufficiency
Worksheet 31-97

Exhibit 31-42 Planning-Level Analysis: Delay and LOS Worksheet 31-98

Exhibit 31-43 Control Delay Field Study Worksheet 31-101

Exhibit 31-44 Acceleration–Deceleration Correction Factor 31-103

Exhibit 31-45 Example Control Delay Field Study Worksheet..... 31-104

Exhibit 31-46 Example Worksheet with Residual Queue at End 31-105

Exhibit 31-47 Saturation Flow Rate Field Study Worksheet 31-107

Exhibit 31-48 Methodology Flowchart..... 31-111

Exhibit 31-49 Setup Module 31-112

Exhibit 31-50 Signalized Intersection Module 31-112

Exhibit 31-51 Initial Queue Delay Module 31-113

Exhibit 31-52 Performance Measures Module 31-113

Exhibit 31-53 Setup Module Routines..... 31-114

Exhibit 31-54 Signalized Intersection Module: Main Routines 31-115

Exhibit 31-55 Signalized Intersection Module: ComputeQAPolygon
Routines..... 31-117

Exhibit 31-56 Performance Measures Module Routines 31-118

Exhibit 31-57 Effect of Storage Bay Length on Throughput and Delay 31-120

Exhibit 31-58 Effect of Storage Bay Length on Capacity	31-121
Exhibit 31-59 Effect of Right-Turn-on-Red and Lane Allocation on Delay	31-122
Exhibit 31-60 Effect of Right-Turn-on-Red and Right-Turn Volume on Delay	31-123
Exhibit 31-61 Effect of Right-Turn-on-Red and Right-Turn Protection on Delay	31-124
Exhibit 31-62 Closely Spaced Intersections	31-125
Exhibit 31-63 Effect of Closely Spaced Intersections on Capacity and Delay	31-126
Exhibit 31-64 Example Problems.....	31-127
Exhibit 31-65 Example Problem 1: Intersection Plan View	31-127
Exhibit 31-66 Example Problem 1: Traffic Characteristics Data	31-128
Exhibit 31-67 Example Problem 1: Geometric Design Data	31-128
Exhibit 31-68 Example Problem 1: Signal Control Data	31-128
Exhibit 31-69 Example Problem 1: Other Data.....	31-129
Exhibit 31-70 Example Problem 1: Movement Groups and Lane Groups.....	31-130
Exhibit 31-71 Example Problem 1: Movement Group Flow Rates.....	31-130
Exhibit 31-72 Example Problem 1: Lane Group Flow Rates	31-130
Exhibit 31-73 Example Problem 1: Adjusted Saturation Flow Rate.....	31-131
Exhibit 31-74 Example Problem 1: Proportion Arriving During Green.....	31-132
Exhibit 31-75 Example Problem 1: Signal Phase Duration.....	31-133
Exhibit 31-76 Example Problem 1: Capacity and Volume-to-Capacity Ratio	31-133
Exhibit 31-77 Example Problem 1: Control Delay	31-134
Exhibit 31-78 Example Problem 1: Back of Queue and Queue Storage Ratio	31-134
Exhibit 31-79 Example Problem 1: Queue Accumulation Polygon.....	31-135
Exhibit 31-80 Example Problem 2: Pedestrian Flow Rates.....	31-135
Exhibit 31-81 Example Problem 2: Vehicular Demand Flow Rates	31-136
Exhibit 31-82 Example Problem 3: Vehicular Demand Flow Rates and Cross-Section Element Widths.....	31-141

1. INTRODUCTION

Chapter 31 is the supplemental chapter for Chapter 19, Signalized Intersections, which is found in Volume 3 of the *Highway Capacity Manual* (HCM). This chapter presents detailed information about the following aspects of the Chapter 19 motorized vehicle methodology:

- Procedures are described for computing actuated phase duration and pretimed phase duration.
- Procedures are described for computing saturation flow rate adjustment factors to account for the presence of pedestrians, bicycles, and work zones.
- A procedure is described for computing uniform delay by using the queue accumulation polygon (QAP) concept. The procedure is extended to shared-lane lane groups and lane groups with permitted turn movements.
- A procedure is described for computing queue length and queue storage ratio.

This chapter provides a simplified version of the Chapter 19 motorized vehicle methodology that is suitable for planning applications. The chapter also describes techniques for measuring control delay and saturation flow rate in the field and provides details about the computational engine that implements the Chapter 19 motorized vehicle methodology. Finally, this chapter provides three example problems that demonstrate the application of the motorized vehicle, pedestrian, and bicycle methodologies to a signalized intersection.

VOLUME 4: APPLICATIONS GUIDE

25. Freeway Facilities: Supplemental
26. Freeway and Highway Segments: Supplemental
27. Freeway Weaving: Supplemental
28. Freeway Merges and Diverges: Supplemental
29. Urban Street Facilities: Supplemental
30. Urban Street Segments: Supplemental
- 31. Signalized Intersections: Supplemental**
32. STOP-Controlled Intersections: Supplemental
33. Roundabouts: Supplemental
34. Interchange Ramp Terminals: Supplemental
35. Pedestrians and Bicycles: Supplemental
36. Concepts: Supplemental
37. ATDM: Supplemental

2. CAPACITY AND PHASE DURATION

This section describes five procedures related to the calculation of capacity and phase duration. The first procedure is used to calculate the average duration of an actuated phase, and the second is used to calculate the lane volume distribution on multilane intersection approaches. The third procedure focuses on the calculation of phase duration for pretimed intersection operation. The fourth procedure is used to compute the pedestrian and bicycle saturation flow rate adjustment factors, and the fifth computes the work zone saturation flow rate adjustment factor. Each procedure is described in a separate subsection.

ACTUATED PHASE DURATION

This subsection describes a procedure for estimating the average phase duration for an intersection that is operating with actuated control. When appropriate, the description is extended to include techniques for estimating the duration of noncoordinated and coordinated phases. Unless stated otherwise, a noncoordinated phase is modeled as an actuated phase in this methodology.

This subsection consists of the following seven parts:

- Concepts,
- Volume computations,
- Queue accumulation polygon,
- Maximum allowable headway,
- Equivalent maximum green,
- Average phase duration, and
- Probability of max-out.

The last six parts in the list above describe a series of calculations that are completed in the sequence shown to obtain estimates of average phase duration and the probability of phase termination by extension to its maximum green limit (i.e., max-out).

Concepts

The duration of an actuated phase is composed of five time periods, as shown in Equation 31-1. The first period represents the time lost while the queue reacts to the signal indication changing to green. The second interval represents the effective green time associated with queue clearance. The third period represents the time the green indication is extended by randomly arriving vehicles. It ends when there is a gap in traffic (i.e., gap-out) or a max-out. The fourth period represents the yellow change interval, and the last period represents the red clearance interval.

Equation 31-1

$$D_p = l_1 + g_s + g_e + Y + R_c$$

where

$$D_p = \text{phase duration (s),}$$

- l_1 = start-up lost time = 2.0 (s),
- Y = yellow change interval (s),
- R_c = red clearance interval (s),
- g_s = queue service time (s),
- g_e = green extension time (s).

The relationship between the variables in Equation 31-1 is shown in Exhibit 31-1 with a QAP. Key variables shown in the exhibit are defined for Equation 31-1 and in the following list:

- q_r = arrival flow rate during the effective red time = $(1 - P) q C/r$ (veh/s),
- P = proportion of vehicles arriving during the green indication (decimal),
- r = effective red time = $C - g$ (s),
- g = effective green time (s),
- s = adjusted saturation flow rate (veh/h/ln),
- q_g = arrival flow rate during the effective green time = $P q C/g$ (veh/s),
- q = arrival flow rate (veh/s),
- Q_r = queue size at the end of the effective red time = $q_r r$ (veh),
- l_2 = clearance lost time = $Y + R_c - e$ (s), and
- e = extension of effective green = 2.0 (s).

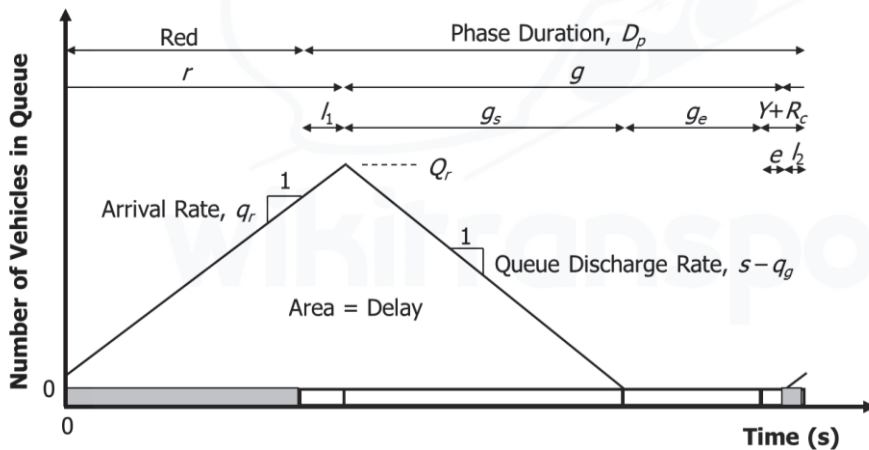

Exhibit 31-1
Time Elements Influencing
Actuated Phase Duration

Exhibit 31-1 shows the relationship between phase duration and queue size for the average signal cycle. During the red interval, vehicles arrive at a rate of q_r and form a queue. The queue reaches its maximum size l_1 seconds after the green interval starts. At this time, the queue begins to discharge at a rate equal to the saturation flow rate s less the arrival rate during green q_g . The queue clears g_s seconds after it first begins to discharge. Thereafter, random vehicle arrivals are detected and cause the green interval to be extended. Eventually, a gap occurs in traffic (or the maximum green limit is reached), and the green interval ends. The end of the green interval coincides with the end of the extension time g_e .

Equation 31-2

The effective green time for the phase is computed with Equation 31-2.

$$\begin{aligned} g &= D_p - l_1 - l_2 \\ &= g_s + g_e + e \end{aligned}$$

where all variables are as previously defined.

Coordinated Phase Duration

The duration of a coordinated phase is dictated by the cycle length and the force-off settings for the noncoordinated phases. These settings define the points in the signal cycle at which each noncoordinated phase must end. The force-off settings are used to ensure the coordinated phases receive a green indication at a specific time in the cycle. Presumably, this time is synchronized with the coordinated phase time at the adjacent intersections so that traffic progresses along the street segment. In general, the duration of a coordinated phase is equal to the cycle length less the time allocated to the conflicting phase in the same ring and less the time allocated to the minor-street phases. Detectors are not typically assigned to the coordinated phase, and this phase is not typically extended by the vehicles it serves.

Noncoordinated Phase Duration

The duration of a noncoordinated phase is dictated by traffic demand in much the same manner as for an actuated phase. However, the noncoordinated phase duration is typically constrained by its force-off setting (rather than a maximum green setting). A noncoordinated phase is referred to here and modeled as an *actuated* phase.

Right-Turn Overlap Duration

If a right-turn lane group is operated in a protected or protected-permitted mode, then the protected indication is assumed to be provided as a right-turn overlap with the complementary left-turn phase on the intersecting roadway. In this manner, the right-turn protected interval duration is dictated by the duration of the complementary left-turn phase (which is determined by the left-turn phase settings, left-turn detection, and left-turn volume). The procedures described in this subsection are used to determine the average duration of the complementary left-turn lane phase (and thus the protected right-turn interval duration).

The right-turn permitted interval duration is dictated by the phase settings, detection, and volume associated with the right-turn movement and its adjacent through movement. The procedures described in this subsection are used to determine the average duration of the phase serving the right-turn movement in a permitted manner.

Volume Computations

This subsection describes the calculations needed to quantify the time rate of calls submitted to the controller by the detectors. Two call rates are computed for each signal phase. The first rate represents the flow rate of calls for green extension that arrive during the green interval. The second call rate represents the flow rate of calls for phase activation that arrive during the red indication.

A. Call Rate to Extend Green

The call rate to extend the green indication for a given phase is based on the flow rate of the lane groups served by the phase. The call rate is represented in the analysis by the flow rate parameter. This parameter represents an adjusted flow rate that accounts for the tendency of drivers to form “bunches” (i.e., randomly formed platoons). The flow rate parameter for the phase is computed as shown by Equation 31-3 with Equation 31-4 and Equation 31-5.

$$\lambda^* = \sum_{i=1}^m \lambda_i$$

Equation 31-3

with

$$\lambda_i = \frac{\phi_i q_i}{1 - \Delta_i q_i}$$

Equation 31-4

$$\phi_i = e^{-b_i \Delta_i q_i}$$

Equation 31-5

where

- λ^* = flow rate parameter for the phase (veh/s);
- λ_i = flow rate parameter for lane group i ($i = 1, 2, \dots, m$) (veh/s);
- ϕ_i = proportion of free (unbunched) vehicles in lane group i (decimal);
- q_i = arrival flow rate for lane group $i = v_i/3,600$ (veh/s);
- v_i = demand flow rate for lane group i (veh/h);
- Δ_i = headway of bunched vehicle stream in lane group i ; = 1.5 s for single-lane lane group, 0.5 s otherwise (s/veh);
- m = number of lane groups served during the phase; and
- b_i = bunching factor for lane group i (0.6, 0.5, and 0.8 for lane groups with 1, 2, and 3 or more lanes, respectively).

Using Equation 31-6, Equation 31-7, and Equation 31-8, it is also useful to compute the following three variables for each phase. These variables are used in a later step to compute green extension time.

$$\phi^* = e^{-\sum_{i=1}^m b_i \Delta_i q_i}$$

Equation 31-6

$$\Delta^* = \frac{\sum_{i=1}^m \lambda_i \Delta_i}{\lambda^*}$$

Equation 31-7

$$q^* = \sum_{i=1}^m q_i$$

Equation 31-8

where

- ϕ^* = combined proportion of free (unbunched) vehicles for the phase (decimal),
- Δ^* = equivalent headway of bunched vehicle stream served by the phase (s/veh), and
- q^* = arrival flow rate for the phase (veh/s), and

all other variables are as previously defined.

The call rate for green extension for a phase that does not end at a barrier is equal to the flow rate parameter λ^* . If two phases terminate at a common barrier (i.e., one phase in each ring) and simultaneous gap-out is enabled, then the call rate for either phase is based on the combined set of lane groups being served by the two phases. To model this behavior, the lane group parameters for each phase are combined to estimate the call rate for green extension. Specifically, the variable m in the preceding six equations is modified to represent the combined number of lane groups served by both phases.

The following rules are evaluated to determine the number of lane groups served m if simultaneous gap-out is enabled. They are described for the case in which Phases 2, 6, 4, and 8 end at the barrier (as shown in Exhibit 19-2). The rules should be modified if other phase pairs end at the barrier.

1. If Phases 2 and 6 have simultaneous gap-out enabled, then the lane groups associated with Phase 2 are combined with the lane groups associated with Phase 6 in applying Equation 31-3 through Equation 31-8 for Phase 6. Similarly, the lane groups associated with Phase 6 are combined with the lane groups associated with Phase 2 in applying these equations for Phase 2.
2. If Phases 4 and 8 have simultaneous gap-out enabled, then the lane groups associated with Phase 4 are combined with the lane groups associated with Phase 8 in evaluating Phase 8. Similarly, the lane groups associated with Phase 8 are combined with the lane groups associated with Phase 4 in evaluating Phase 4.

B. Call Rate to Activate a Phase

The call rate to activate a phase is used to determine the probability that the phase is activated in the forthcoming cycle sequence. This rate is based on the arrival flow rate of the traffic movements served by the phase and whether the phase is associated with dual entry. Vehicles or pedestrians can call a phase, so a separate call rate is computed for each traffic movement.

i. Determine Phase Vehicular Flow Rate. The vehicular flow rate associated with a phase depends on the type of movements it serves as well as the approach lane allocation. The following rules apply in determining the phase vehicular flow rate:

1. If the phase exclusively serves a left-turn movement, then the phase vehicular flow rate is equal to the left-turn movement flow rate.
2. If the phase serves a through or right-turn movement and there is no exclusive left-turn phase for the adjacent left-turn movement, then the phase vehicular flow rate equals the approach flow rate.
3. If the phase serves a through or right-turn movement and there is an exclusive left-turn phase for the adjacent left-turn movement, then
 - a. If there is a left-turn bay, then the phase vehicular flow rate equals the sum of the through and right-turn movement flow rates.
 - b. If there is no left-turn bay, then the phase vehicular flow rate equals the approach flow rate.

- c. If split phasing is used, then the phase vehicular flow rate equals the approach flow rate.

ii. *Determine Activating Vehicular Call Rate.* The activating vehicular call rate q_v^* is equal to the phase vehicular flow rate divided by 3,600 to convert it to units of vehicles per second. If dual entry is activated for a phase, then the activation call rate must be modified by adding its original rate to that of both concurrent phases. For example, if Phase 2 is set for dual entry, then the modified Phase 2 activation call rate equals the original Phase 2 activation call rate plus the activation rate of Phase 5 and the activation rate of Phase 6. In this manner, Phase 2 is activated when demand is present for Phase 2, 5, or 6.

iii. *Determine Activating Pedestrian Call Rate.* The activating pedestrian call rate q_p^* is equal to the pedestrian flow rate associated with the subject approach divided by 3,600 to convert it to units of pedestrians per second. If dual entry is activated for a phase, then the activation call rate must be modified by adding its original rate to that of the opposing through phase. For example, if Phase 2 is set for dual entry, then the modified Phase 2 activation call rate equals the original Phase 2 activation call rate plus the activation rate of Phase 6. In this manner, Phase 2 is activated when pedestrian demand is present for Phase 2 or 6.

Queue Accumulation Polygon

This subsection summarizes the procedure used to construct the QAP associated with a lane group. This polygon defines the queue size for a traffic movement as a function of time during the cycle. The procedure is described more fully in Section 3; it is discussed here to illustrate its use in calculating queue service time.

For polygon construction, all flow rate variables are converted to common units of vehicles per second per lane. The presentation in this subsection is based on these units for q and s . If the flow rate q exceeds the lane capacity, then it is set to equal this capacity.

A polygon is shown in Exhibit 31-1 for a through movement in an exclusive lane. At the start of the effective red, vehicles arrive at a rate of q_r and accumulate to a length of Q_r vehicles at the time the effective green begins. Thereafter, the queue begins to discharge at a rate of $s - q_g$ until it clears after g_s seconds. The queue service time g_s represents the time required to serve the queue present at the end of effective red Q_r , plus any additional arrivals that join the queue before it fully clears. Queue service time is computed as $Q_r / (s - q_g)$. Substituting the variable relationships in the previous variable list into this equation yields Equation 31-9 for estimating queue service time.

$$g_s = \frac{q C (1 - P)}{\frac{s}{3,600} - q C (P/g)}$$

Equation 31-9

where P is the proportion of vehicles arriving during the green indication (decimal), s is the adjusted saturation flow rate (veh/h/ln), and all other variables are as previously defined.

The polygon in Exhibit 31-1 applies to some types of lane groups. Other polygon shapes are possible. A detailed procedure for constructing polygons is described in Section 3.

Maximum Allowable Headway

This subsection describes a procedure for calculating the maximum allowable headway (MAH) for the detection associated with a phase. It consists of two steps. Step A computes MAH for each lane group served by the subject phase. Step B combines MAH into an equivalent MAH for the phase. The latter step is used when a phase serves two or more lane groups or when simultaneous gap-out is enabled.

The procedure addresses the situation in which there is one zone of detection per lane. This type of detection is referred to here as *stop-line detection* because the detection zone is typically located at the stop line. However, some agencies prefer to locate the detection zone at a specified distance upstream from the stop line. This procedure can be used to evaluate any single-detector-per-lane design, provided the detector is located so that only the subject traffic movement travels over this detector during normal operation.

The detector length and detection mode input data are specified by movement group. When these data describe a through movement group, it is reasonable to assume they also describe the detection in any shared-lane lane groups that serve the through movement. This assumption allows the movement group inputs to describe the associated lane group values, and the analysis can proceed on a lane-group basis. However, if this assumption is not valid or if information about the detection design for each lane is known, then the procedure can be extended to the calculation of MAH for each lane. The lane-specific MAHs would then be combined for the phase that serves these lanes.

Concepts

MAH represents the maximum time that can elapse between successive calls for service without terminating the phase by gap-out. It is useful for describing the detection design and signal settings associated with a phase. MAH depends on the number of detectors serving the lane group, the length of these detectors, and the average vehicle speed in the lane group.

The relationship between passage time PT , detection zone length L_{ds} , vehicle length L_v , average speed S_a , and MAH is shown in Exhibit 31-2. The two vehicles shown are traveling from left to right and have a headway equal to MAH so that the second vehicle arrives at the detector the instant the passage time is set to time out.

Exhibit 31-2
Detection Design and
Maximum Allowable Headway

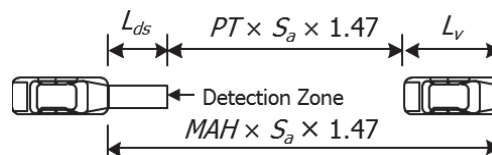

According to Exhibit 31-2, Equation 31-10 with Equation 31-11 can be derived for estimating MAH for stop-line detection operating in the presence mode.

$$MAH = PT + \frac{L_{ds} + L_v}{1.47 S_a}$$

Equation 31-10

with

$$L_v = L_{pc}(1 - 0.01 P_{HV}) + 0.01 L_{HV}P_{HV} - D_{sv}$$

Equation 31-11

where

MAH = maximum allowable headway (s/veh),

PT = passage time setting (s),

L_{ds} = length of the stop-line detection zone (ft),

L_v = detected length of the vehicle (ft),

S_a = average speed on the intersection approach (mi/h),

L_{pc} = stored passenger car lane length = 25 (ft),

P_{HV} = percentage heavy vehicles in the corresponding movement group (%),

L_{HV} = stored heavy-vehicle lane length = 45 (ft), and

D_{sv} = distance between stored vehicles = 8 (ft).

The average speed on the intersection approach can be estimated with Equation 31-12.

$$S_a = 0.90 (25.6 + 0.47 S_{pl})$$

Equation 31-12

where S_{pl} is the posted speed limit (mi/h).

Equation 31-10 is derived for the typical case in which the detection unit is operating in the presence mode. If it is operating in the pulse mode, then MAH equals the passage time setting PT .

A. Determine Maximum Allowable Headway

Equation 31-10 has been modified to adapt it to various combinations of lane use and left-turn operation. A family of equations is presented in this step. The appropriate equation is selected for the subject lane group and then used to compute the corresponding MAH.

The equations presented in this step are derived for the typical case in which the detection unit is operating in the presence mode. If a detector is operating in the pulse mode, then MAH equals the passage time setting PT .

MAH for lane groups serving through vehicles is calculated with Equation 31-13.

$$MAH_{th} = PT_{th} + \frac{L_{ds,th} + L_v}{1.47 S_a}$$

Equation 31-13

where

MAH_{th} = maximum allowable headway for through vehicles (s/veh),

PT_{th} = passage time setting for phase serving through vehicles (s),

$L_{ds,th}$ = length of the stop-line detection zone in the through lanes (ft), and

S_a = average speed on the intersection approach (mi/h).

MAH for a left-turn movement served in exclusive lanes with the protected mode (or protected-permitted mode) is based on Equation 31-13, but the equation is adjusted as shown in Equation 31-14 to account for the slower speed of the left-turn movement.

Equation 31-14

$$MAH_{lt,e,p} = PT_{lt} + \frac{L_{ds,lt} + L_v}{1.47 S_a} + \frac{E_L - 1}{s_o/3,600}$$

where

$MAH_{lt,e,p}$ = maximum allowable headway for protected left-turning vehicles in exclusive lane (s/veh),

PT_{lt} = passage time setting for phase serving the left-turning vehicles (s),

$L_{ds,lt}$ = length of the stop-line detection zone in the left-turn lanes (ft),

E_L = equivalent number of through cars for a protected left-turning vehicle = 1.05, and

s_o = base saturation flow rate (pc/h/ln).

MAH for left-turning vehicles served in a shared lane with the protected-permitted mode is calculated as shown in Equation 31-15.

Equation 31-15

$$MAH_{lt,s,p} = MAH_{th} + \frac{E_L - 1}{s_o/3,600}$$

where $MAH_{lt,s,p}$ is the maximum allowable headway for protected left-turning vehicles in a shared lane (s/veh).

MAH for left-turning vehicles served in an exclusive lane with the permitted mode is adjusted to account for the longer headway of the turning vehicle. In this case, the longer headway includes the time spent waiting for an acceptable gap in the opposing traffic stream. Equation 31-16 addresses these adjustments.

Equation 31-16

$$MAH_{lt,e} = PT_{th} + \frac{L_{ds,lt} + L_v}{1.47 S_a} + \frac{3,600}{s_l} - t_{fh}$$

where

$MAH_{lt,e}$ = maximum allowable headway for permitted left-turning vehicles in exclusive lane (s/veh),

s_l = saturation flow rate in exclusive left-turn lane group with permitted operation (veh/h/ln), and

t_{fh} = follow-up headway = 2.5 (s).

MAH for right-turning vehicles served in an exclusive lane with the protected mode is computed with Equation 31-17.

Equation 31-17

$$MAH_{rt,e,p} = PT_{rt} + \frac{L_{ds,rt} + L_v}{1.47 S_a} + \frac{E_R - 1}{s_o/3,600}$$

where

$MAH_{rt,e,p}$ = maximum allowable headway for protected right-turning vehicles in exclusive lane (s/veh),

PT_{rt} = passage time setting for phase serving right-turning vehicles (s),

E_R = equivalent number of through cars for a protected right-turning vehicle = 1.18, and

$L_{ds,rt}$ = length of the stop-line detection zone in the right-turn lanes (ft).

If the variable E_R in Equation 31-17 is divided by the pedestrian-bicycle saturation flow rate adjustment factor f_{Rpb} and PT_{th} is substituted for PT_{rt} , then the equation can be used to estimate $MAH_{rt,e}$ for permitted right-turning vehicles in an exclusive lane.

Equation 31-18 and Equation 31-19, respectively, are used to estimate MAH for left- and right-turning vehicles that are served in a shared lane with the permitted mode.

$$MAH_{lt,s} = MAH_{th} + \frac{3,600}{s_l} - t_{fh}$$

Equation 31-18

$$MAH_{rt,s} = MAH_{th} + \frac{(E_R/f_{Rpb}) - 1}{s_o/3,600}$$

Equation 31-19

where $MAH_{lt,s}$ is the maximum allowable headway for permitted left-turning vehicles in a shared lane (s/veh), and $MAH_{rt,s}$ is the maximum allowable headway for permitted right-turning vehicles in a shared lane (s/veh).

B. Determine Equivalent Maximum Allowable Headway

The equivalent MAH (i.e., MAH^*) is calculated for cases in which more than one lane group is served by a phase. It is also calculated for phases that end at a barrier and that are specified in the controller as needing to gap out at the same time as a phase in the other ring. The following rules are used to compute the equivalent MAH:

1. If simultaneous gap-out is not enabled, or the phase does not end at the barrier, then
 - a. If the phase serves only one movement, then MAH^* for the phase equals the MAH computed for the corresponding lane group.
 - b. This rule subset applies when the phase serves all movements and there is no exclusive left-turn phase for the approach (i.e., it operates with the permitted mode). The equations shown apply to the most general case in which a left-turn, through, and right-turn movement exist and a through lane group exists. If any of these movements or lane groups do not exist, then their corresponding flow rate parameter equals 0.0 veh/s.
 - i. If there is no left-turn lane group or right-turn lane group (i.e., shared lanes), then MAH^* for the phase is computed from Equation 31-20.

Equation 31-20

$$MAH^* = \frac{P_L \lambda_{sl} MAH_{lt,s} + [(1 - P_L) \lambda_{sl} + \lambda_t + (1 - P_R) \lambda_{sr}] MAH_{th} + P_R \lambda_{sr} MAH_{rt,s}}{\lambda_{sl} + \lambda_t + \lambda_{sr}}$$

where

λ_{sl} = flow rate parameter for shared left-turn and through lane group (veh/s),

λ_t = flow rate parameter for exclusive through lane group (veh/s),

λ_{sr} = flow rate parameter for shared right-turn and through lane group (veh/s),

P_L = proportion of left-turning vehicles in the shared lane (decimal), and

P_R = proportion of right-turning vehicles in the shared lane (decimal).

- ii. If there is a right-turn lane group but no left-turn lane group, then Equation 31-21 is applicable.

Equation 31-21

$$MAH^* = \frac{P_L \lambda_{sl} MAH_{lt,s} + [(1 - P_L) \lambda_{sl} + \lambda_t] MAH_{th} + \lambda_r MAH_{rt,e}}{\lambda_{sl} + \lambda_t + \lambda_r}$$

where λ_r is the flow rate parameter for the exclusive right-turn lane group (veh/s).

- iii. If there is a left-turn lane group but no right-turn lane group, then MAH^* for the phase is computed with Equation 31-22.

Equation 31-22

$$MAH^* = \frac{\lambda_l MAH_{lt,e} + [\lambda_t + (1 - P_R) \lambda_{sr}] MAH_{th} + P_R \lambda_{sr} MAH_{rt,s}}{\lambda_l + \lambda_t + \lambda_{sr}}$$

where λ_l is the flow rate parameter for the exclusive left-turn lane group (veh/s).

- iv. If there is a left-turn lane group and a right-turn lane group, then MAH^* for the phase is computed with Equation 31-23.

Equation 31-23

$$MAH^* = \frac{\lambda_l MAH_{lt,e} + \lambda_t MAH_{th} + \lambda_r MAH_{rt,e}}{\lambda_l + \lambda_t + \lambda_r}$$

- c. If the phase serves only a through lane group, right-turn lane group, or both, then

- i. If there is a right-turn lane group and a through lane group, then MAH^* for the phase is computed with Equation 31-24.

Equation 31-24

$$MAH^* = \frac{\lambda_t MAH_{th} + \lambda_r MAH_{rt,e}}{\lambda_t + \lambda_r}$$

- ii. If there is a shared right-turn and through lane group, then MAH^* for the phase is computed with Equation 31-25.

Equation 31-25

$$MAH^* = \frac{[\lambda_t + (1 - P_R) \lambda_{sr}] MAH_{th} + P_R \lambda_{sr} MAH_{rt,s}}{\lambda_t + \lambda_{sr}}$$

- d. If the phase serves all approach movements using split phasing, then

- i. If there is one lane group (i.e., a shared lane), then MAH^* for the phase equals the MAH computed for the lane group.

- ii. If there is more than one lane group, then MAH^* is computed with the equations in previous Rule 1.b, but $MAH_{lt,e,p}$ is substituted for $MAH_{lt,e}$, and $MAH_{lt,s,p}$ is substituted for $MAH_{lt,s}$.
 - e. If the phase has protected-permitted operation with a shared left-turn and through lane, then the equations in previous Rule 1.b (i.e., 1.b.i and 1.b.ii) apply. The detection for this operation does not influence the duration of the left-turn phase. The left-turn phase will be set to minimum recall and will extend to its minimum value before terminating.
2. If simultaneous gap-out is enabled and the phase ends at the barrier, then MAH^* for the phase is computed with Equation 31-26, where the summations shown are for all lane groups served by the subject (or concurrent) phase.

$$MAH^* = \frac{MAH \sum \lambda_i + MAH_c \sum \lambda_{c,i}}{\sum \lambda_i + \sum \lambda_{c,i}}$$

Equation 31-26

where

MAH^* = equivalent maximum allowable headway for the phase (s/veh),

MAH_c = maximum allowable headway for the concurrent phase that also ends at the barrier (s/veh), and

$\lambda_{c,i}$ = flow rate parameter for lane group i served in the concurrent phase that also ends at the barrier (veh/s).

When there is split phasing, there are no concurrent phases, and Equation 31-26 does not apply.

Equivalent Maximum Green

In coordinated-actuated operation, the force-off points are used to constrain the duration of the noncoordinated phases. Although the maximum green setting is also available to provide additional constraint, it is not commonly used. In fact, the default mode in most modern controllers is to inhibit the maximum green timer when the controller is used in a coordinated signal system.

The relationship between the force-off points, yield point, and phase splits is shown in Exhibit 31-3. The yield point is associated with the coordinated phases (i.e., Phases 2 and 6). It coincides with the start of the yellow change interval. If a call for service by one of the noncoordinated phases arrives after the yield point is reached, then the coordinated phases begin the termination process by presenting the yellow indication. Calls that arrive before the yield point are not served until the yield point is reached.

The force-off and yield points for common phase pairs are shown in Exhibit 31-3 to occur at the same time. This approach is shown for convenience of illustration. In practice, the two phases may have different force-off or yield points.

A permissive period typically follows the yield point. If a conflicting call arrives during the permissive period, then the phase termination process begins immediately, and all phases associated with conflicting calls are served in sequence. Permissive periods are typically long enough to ensure that all calls for

service are met during the signal cycle. This methodology does not explicitly model permissive periods. It is assumed the permissive period begins at the yield point and is sufficiently long that all conflicting calls are served in sequence each cycle.

One force-off point is associated with each of Phases 1, 3, 4, 5, 7, and 8. If a phase is extended to its force-off point, the phase begins the termination process by presenting the yellow indication (phases that terminate at a barrier must be in agreement to terminate before the yellow indication will be presented). Modern controllers compute the force-off points and yield point by using the entered phase splits and change periods. These computations are based on the relationships shown in Exhibit 31-3.

Exhibit 31-3
Force-Off Points, Yield Point,
and Phase Splits

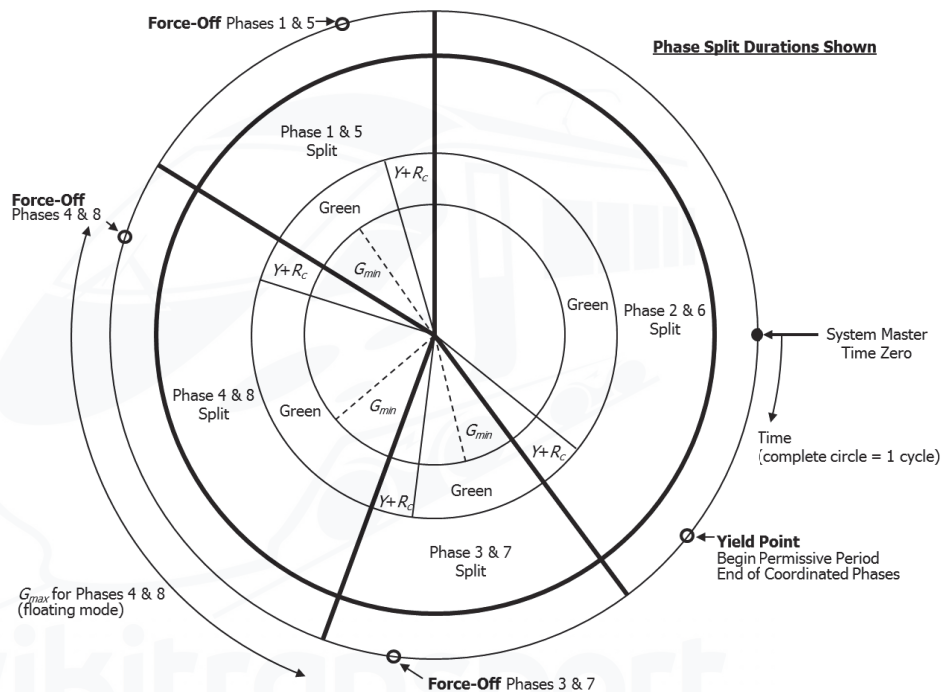

The concept of equivalent maximum green is useful for modeling noncoordinated phase operation. This maximum green replicates the effect of a force-off or yield point on phase duration. The procedure described in this subsection is used to compute the equivalent maximum green for coordinated-actuated operation. Separate procedures are described for the fixed force mode and the floating force mode.

A. Determine Equivalent Maximum Green for Floating Force Mode

This step is applicable if the controller is set to operate in the floating force mode. With this mode, each noncoordinated phase has its force-off point set at the split time after the phase first becomes active. The force-off point for a phase is established when the phase is first activated. Thus, the force-off point “floats,” or changes, each time the phase is activated. This operation allows unused split time to revert to the coordinated phase via an early return to green. The equivalent maximum green for this mode is computed as being equal to the

phase split less the change period. This relationship is shown in Exhibit 31-3 for Phases 4 and 8.

B. Determine Equivalent Maximum Green for Fixed Force Mode

This step is applicable if the controller is set to operate in the fixed force mode. With this mode, each noncoordinated phase has its force-off point set at a fixed time in the cycle relative to time zero on the system master. The force-off points are established whenever a new timing plan is selected (e.g., by time of day) and remains “fixed” until a new plan is selected. This operation allows unused split time to revert to the following phase.

The equivalent maximum green for this mode is computed for each phase by first establishing the fixed force-off points (as shown in Exhibit 31-3) and then computing the average duration of each noncoordinated phase. The calculation process is iterative. For the first iteration, the equivalent maximum green is set equal to the phase split less the change period. Thereafter, the equivalent maximum green for a specific phase is computed as the difference between its force-off point and the sum of the previous phase durations, starting with the first noncoordinated phase. Equation 31-27 illustrates this computation for Phase 4, using the ring structure shown in Exhibit 19-2. A similar calculation is performed for the other phases.

$$G_{max,4} = FO_4 - (YP_2 + CP_2 + G_3 + CP_3)$$

Equation 31-27

where

$G_{max,4}$ = equivalent maximum green for Phase 4 (s),

FO_4 = force-off point for Phase 4 (s),

YP_2 = yield point for Phase 2 (s),

G_3 = green interval duration for Phase 3 (s), and

CP_3 = change period (yellow change interval plus red clearance interval) for Phase 3 (s).

The maximum green obtained from Equation 31-27 is shown in Exhibit 31-4 for the ring that serves Phases 1, 2, 3, and 4. Unlike Exhibit 31-3, Exhibit 31-4 illustrates the *actual* average phase durations for a given cycle. In this example, Phase 3 timed to its minimum green and terminated. It never reached its force-off point. The unused time from Phase 3 was made available to Phase 4, which resulted in a larger maximum green than was obtained with the floating mode (see Exhibit 31-3). If every noncoordinated phase extends to its force-off point, then the maximum green from the fixed force mode equals that obtained from the floating force mode.

Average Phase Duration

This subsection describes the sequence of calculations needed to estimate the average duration of a phase. In fact, the process requires the combined calculation of the duration of all phases together because of the constraints imposed by the controller ring structure and associated barriers.

The calculation process is iterative because several intermediate equations require knowledge of the green interval duration. Specifically, the green interval duration is required in calculating lane group flow rate, queue service time, permitted green time, left-turn volume served during the permitted portion of a protected-permitted mode, and equivalent maximum green. To overcome this circular dependency, the green interval for each phase is initially estimated, and then the procedure is implemented by using this estimate. When completed, the procedure provides a new initial estimate of the green interval duration. The calculations are repeated until the initial estimate and computed green interval duration are effectively equal.

Exhibit 31-4
Example Equivalent Maximum Green for Fixed Force Mode

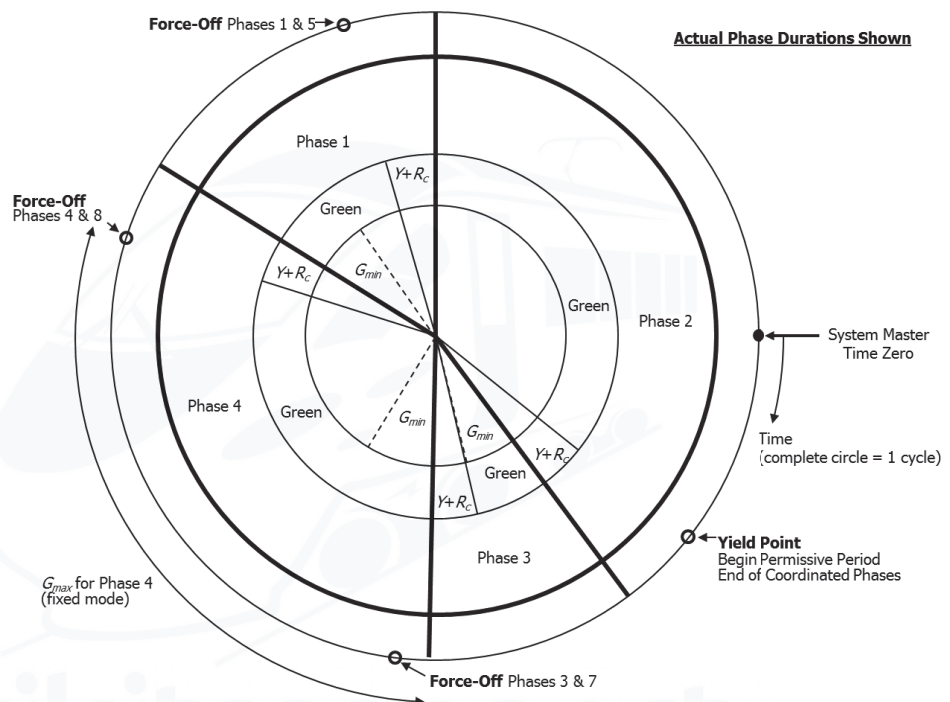

The calculation steps that constitute the procedure are described in the following paragraphs.

A. Compute Effective Change Period

The change period is computed for each phase. It is equal to the sum of the yellow change interval and the red clearance interval (i.e., $Y + R_c$). For phases that end at a barrier, the longer change period of the two phases that terminate at a barrier is used to define the effective change period for both phases.

B. Estimate Green Interval

An initial estimate of the green interval duration is provided for each phase. For the first iteration with fully actuated control, the initial estimate is equal to the maximum green setting. For the first iteration with coordinated-actuated control, the initial estimate is equal to the input phase split less the change period.

C. Compute Equivalent Maximum Green (Coordinated-Actuated)

If the controller is operating as coordinated-actuated, then the equivalent maximum green is computed for each phase. It is based on the estimated green interval duration, phase splits, and change periods. The previous subsection titled Equivalent Maximum Green describes how to compute this value.

D. Construct Queue Accumulation Polygon

The QAP is constructed for each lane group and corresponding phase by using the known flow rates and signal timing. The procedure for constructing this polygon is summarized in the previous subsection titled Queue Accumulation Polygon. It is described in more detail in Section 3.

E. Compute Queue Service Time

The queue service time g_s is computed for each QAP constructed in the previous step. For through movements or left-turn movements served during a left-turn phase, the polygon in Exhibit 31-1 applies and Equation 31-9 can be used. The procedure described in Section 3 is applicable to more complicated polygon shapes.

F. Compute Call Rate to Extend Green

The extending call rate is represented as the flow rate parameter λ . This parameter is computed for each lane group served by an actuated phase and is then aggregated to a phase-specific value. The procedure for computing this parameter is described in the previous subsection titled Volume Computations.

G. Compute Equivalent Maximum Allowable Headway

The equivalent maximum allowable headway MAH^* is computed for each actuated phase. The procedure for computing MAH^* is described in the previous subsection titled Maximum Allowable Headway.

H. Compute Number of Extensions Before Max-Out

The average number of extensions before the phase terminates by max-out is computed for each actuated phase with Equation 31-28.

$$n = q^* [G_{max} - (g_s + l_1)] \geq 0.0$$

Equation 31-28

where n is the number of extensions before the green interval reaches its maximum limit, G_{max} is the maximum green setting (s), and all other variables are as previously defined.

I. Compute Probability of Green Extension

The probability of the green interval being extended by randomly arriving vehicles is computed for each actuated phase with Equation 31-29.

$$p = 1 - \varphi^* e^{-\lambda^* (MAH^* - \Delta^*)}$$

Equation 31-29

where p is the probability of a call headway being less than the maximum allowable headway.

J. Compute Green Extension Time

The average green extension time is computed for each actuated phase with Equation 31-30.

Equation 31-30

$$g_e = \frac{p^2(1 - p^n)}{q^*(1 - p)}$$

K. Compute Activating Call Rate

The call rate to activate a phase is computed for each actuated phase. A separate rate is computed for vehicular traffic and for pedestrian traffic. The rate for each travel mode is based on its flow rate and the use of dual entry. The procedure for computing this rate is described in the previous subsection titled Volume Computations.

L. Compute Probability of Phase Call

The probability that an actuated phase is called depends on whether it is set on recall in the controller. If it is on recall, then the probability that the phase is called equals 1.0. If the phase is not on recall, then the probability that it is called can be estimated by using Equation 31-31 with Equation 31-32 and Equation 31-33.

Equation 31-31

$$p_c = p_v(1 - p_p) + p_p(1 - p_v) + p_v p_p$$

with

Equation 31-32

$$p_v = 1 - e^{-q_v^* C}$$

Equation 31-33

$$p_p = 1 - e^{-q_p^* P_p C}$$

where

p_c = probability that the subject phase is called,

p_v = probability that the subject phase is called by a vehicle detection,

p_p = probability that the subject phase is called by a pedestrian detection,

q_v^* = activating vehicular call rate for the phase (veh/s),

q_p^* = activating pedestrian call rate for the phase (p/s), and

P_p = probability of a pedestrian pressing the detector button = 0.51.

The probability of a pedestrian pressing the detector button reflects the tendency of some pedestrians to decline from using the detector button before crossing a street. Research indicates about 51% of all crossing pedestrians will push the button to place a call for pedestrian service (1).

M. Compute Unbalanced Green Duration

The unbalanced average green interval duration is computed for each actuated phase by using Equation 31-34 with Equation 31-35 and Equation 31-36.

Equation 31-34

$$G_u = G_{|veh,call} p_v(1 - p_p) + G_{|ped,call} p_p(1 - p_v) + \max(G_{|veh,call}, G_{|ped,call}) p_v p_p \leq G_{max}$$

with

Equation 31-35

$$G_{|veh,call} = \max(l_1 + g_s + g_e, G_{min})$$

$$G_{|ped,call} = Walk + PC$$

Equation 31-36

where

G_u = unbalanced green interval duration for a phase (s),

$G_{|veh,call}$ = average green interval given that the phase is called by a vehicle detection (s),

G_{min} = minimum green setting (s),

$G_{|ped,call}$ = average green interval given that the phase is called by a pedestrian detection (s),

Walk = pedestrian walk setting (s), and

PC = pedestrian clear setting (s).

If maximum recall is set for the phase, then G_u is equal to G_{max} . If the phase serves a left-turn movement that operates in the protected mode, then the probability that it is called by pedestrian detection p_p is equal to 0.0.

If the phase serves a left-turn movement that operates in the protected-permitted mode and the left-turn movement shares a lane with through vehicles, then the green interval duration is equal to the phase's minimum green setting.

The green interval duration obtained from this step is "unbalanced" because it does not reflect the constraints imposed by the controller ring structure and associated barriers. These constraints are imposed in Step O or Step P, depending on the type of control used at the intersection.

It is assumed the rest-in-walk mode is not enabled.

N. Compute Unbalanced Phase Duration

The unbalanced average phase duration is computed for each actuated phase by adding the unbalanced green interval duration and the corresponding change period components. This calculation is completed with Equation 31-37.

$$D_{up} = G_u + Y + R_c$$

Equation 31-37

where D_{up} is the unbalanced phase duration (s).

If simultaneous gap-out is enabled, the phase ends at a barrier, and the subject phase experiences green extension when the concurrent phase has reached its maximum green limit, then both phases are extended, but only due to the call flow rate of the subject phase. Hence, the green extension time computed in Step J is too long. The effect is accounted for in the current step by multiplying the green extension time from Step J by a "flow rate ratio." This ratio represents the sum of the flow rate parameter for each lane group served by the subject phase divided by the sum of the flow rate parameter for each group served by the subject phase and served by the concurrent phase (the latter sum equals the call rate from Step F).

O. Compute Average Phase Duration—Fully Actuated Control

For this discussion, it is assumed Phases 2 and 6 are serving Movements 2 and 6, respectively, on the major street (see Exhibit 19-2). If the left-turn

movements on the major street operate in the protected mode or the protected-permitted mode, then Movements 1 and 5 are served during Phases 1 and 5, respectively. Similarly, Phases 4 and 8 are serving Movements 4 and 8, respectively, on the minor street. If the left-turn movements on the minor street are protected or protected-permitted, then Phases 3 and 7 are serving Movements 3 and 7, respectively. If a through movement phase occurs first in a phase pair, then the other phase (i.e., the one serving the opposing left-turn movement) is a lagging left-turn phase.

The following rules are used to estimate the average duration of each phase:

1. Given two phases that occur in sequence between barriers (i.e., phase a followed by phase b), the duration of $D_{p,a}$ is equal to the unbalanced phase duration of the first phase to occur (i.e., $D_{p,a} = D_{up,a}$). The duration of $D_{p,b}$ is based on Equation 31-38 for the major-street phases.

Equation 31-38

$$D_{p,b} = \max(D_{up,1} + D_{up,2}, D_{up,5} + D_{up,6}) - D_{p,a}$$

where

- $D_{p,b}$ = phase duration for phase b , which occurs just after phase a (s);
- $D_{p,a}$ = phase duration for phase a , which occurs just before phase b (s); and
- $D_{up,i}$ = unbalanced phase duration for phase i ; $i = 1, 2, 5,$ and 6 for major street, and $i = 3, 4, 7,$ and 8 for minor street (s).

Equation 31-39 applies for the minor-street phases.

Equation 31-39

$$D_{p,b} = \max(D_{up,3} + D_{up,4}, D_{up,7} + D_{up,8}) - D_{p,a}$$

For example, if the phase pair consists of Phase 3 followed by Phase 4 (i.e., a leading left-turn arrangement), then $D_{p,3}$ is set to equal $D_{up,3}$ and $D_{p,4}$ is computed from Equation 31-39. In contrast, if the pair consists of Phase 8 followed by Phase 7 (i.e., a lagging left-turn arrangement), then $D_{p,8}$ is set to equal $D_{up,8}$ and $D_{p,7}$ is computed from Equation 31-39.

2. If an approach is served with one phase operating in the permitted mode (but not split phasing), then $D_{p,a}$ equals 0.0, and the equations above are used to estimate the duration of the phase (i.e., $D_{p,b}$).
3. If split phasing is used, then $D_{p,a}$ equals the unbalanced phase duration for one approach and $D_{p,b}$ equals the unbalanced phase duration for the other approach.

P. Compute Average Phase Duration—Coordinated-Actuated Control

For this discussion, it is assumed Phases 2 and 6 are the coordinated phases serving Movements 2 and 6, respectively (see Exhibit 19-2). If the left-turn movements operate in the protected mode or the protected-permitted mode, then the opposing left-turn movements are served during Phases 1 and 5. If a coordinated phase occurs first in the phase pair, then the other phase (i.e., the one serving the opposing left-turn movement) is a lagging left-turn phase.

The following rules are used to estimate the average duration of each phase:

1. If the phase is associated with the street serving the coordinated movements, then
 - a. If a left-turn phase exists for the subject approach, then its duration $D_{p,l}$ equals $D_{up,l}$ and the opposing through phase has a duration $D_{p,t}$ which is calculated by using Equation 31-40.

$$D_{p,t} = C - \max(D_{up,3} + D_{up,4}, D_{up,7} + D_{up,8}) - D_{p,l}$$

Equation 31-40

where $D_{p,t}$ is the phase duration for coordinated phase t ($t = 2$ or 6) (s), $D_{p,l}$ is the phase duration for left-turn phase l ($l = 1$ or 5) (s), and all other variables are as previously defined.

If Equation 31-40 is applied to Phase 2, then t equals 2 and l equals 1. If it is applied to Phase 6, then t equals 6 and l equals 5.

- b. If a left-turn phase does not exist for the subject approach, then $D_{p,l}$ equals 0.0, and Equation 31-40 is used to estimate the duration of the coordinated phase.

This procedure for determining average phase duration accommodates split phasing only on the street that does not serve the coordinated movements.

If $D_{p,t}$ obtained from Equation 31-40 is less than the minimum phase duration ($= G_{min} + Y + R_c$), then the phase splits are too generous and do not leave adequate time for the coordinated phases.

2. If the phase is associated with the street serving the noncoordinated movements, then the rules described in Step O are used to determine the phase's average duration.

Q. Compute Green Interval Duration

The average green interval duration is computed for each phase by subtracting the yellow change and red clearance intervals from the average phase duration.

$$G = D_p - Y - R_c$$

Equation 31-41

where G is the green interval duration (s).

R. Compare Computed and Estimated Green Interval Durations

The green interval duration from the previous step is compared with the value estimated in Step B. If the two values differ by 0.1 s or more, then the computed green interval becomes the new initial estimate, and the sequence of calculations is repeated starting with Step C. This process is repeated until the two green intervals differ by less than 0.1 s.

If the intersection is semiactuated or fully actuated, then the equilibrium cycle length is computed with Equation 31-42.

$$C_e = \sum_{i=1}^4 D_{p,i}$$

Equation 31-42

where C_e is the equilibrium cycle length (s) and i is the phase number. The sum in this equation includes all phases in Ring 1. The equilibrium cycle length is used in all subsequent calculations in which cycle length C is an input variable.

Probability of Max-Out

When the green indication is extended to its maximum green limit, the associated phase is considered to have terminated by max-out. The probability of max-out provides useful information about phase performance. When max-out occurs, the phase ends without consideration of whether the queue is served or vehicles are in the dilemma zone. Hence, a phase that frequently terminates by max-out may have inadequate capacity and may be associated with more frequent rear-end crashes.

The probability of max-out can be equated to the joint probability of there being a sequence of calls to the phase in service, each call having a headway that is shorter than the equivalent maximum allowable headway for the phase. This probability can be stated mathematically by using Equation 31-43 with Equation 31-44 and Equation 31-45.

Equation 31-43

$$p_x = p^{n_x}$$

with

Equation 31-44

$$n_x = \frac{G_{max} - MAH^* - (g_s + l_1)}{h} \geq 0.0$$

Equation 31-45

$$h = \frac{\Delta^* + (\varphi^*/\lambda^*) - (MAH^* + [1/\lambda^*]\varphi^*e^{-\lambda^*(MAH^*-\Delta^*)})}{1 - \varphi^*e^{-\lambda^*(MAH^*-\Delta^*)}}$$

where

p_x = probability of phase termination by extension to the maximum green limit,

h = average call headway for all calls with headways less than MAH^* (s), and

n_x = number of calls necessary to extend the green to max-out.

LANE GROUP FLOW RATE ON MULTIPLE-LANE APPROACHES

Introduction

When drivers approach an intersection, their primary criterion for lane choice is movement accommodation (i.e., left, through, or right). If multiple exclusive lanes are available to accommodate their movement, they tend to choose the lane that minimizes their service time (i.e., the time required to reach the stop line, as influenced by the number and type of vehicles between them and the stop line). This criterion tends to result in relatively equal lane use under most circumstances.

If one of the lanes being considered is a shared lane, then service time is influenced by the distribution of turning vehicles in the shared lane. Turning vehicles tend to have a longer service time because of the turn maneuver. Moreover, when turning vehicles operate in the permitted mode, their service time can be lengthy because of the gap search process.

Observation of driver lane-choice behavior indicates there is an equilibrium lane flow rate that characterizes the collective choices of the population of drivers. Research indicates the equilibrium flow rate can be estimated from the lane volume distribution that yields the minimum service time for the population of drivers having a choice of lanes (2).

A model for predicting the equilibrium lane flow rate on an intersection approach is described in this subsection. The model is based on the principle that through drivers will choose the lane that minimizes their perceived service time. As a result of this lane selection process, each lane will have the same minimum service time. The principle is represented mathematically by (a) defining service time for each lane as the product of lane flow rate and saturation headway, (b) representing this product as the lane demand-to-saturation flow rate ratio (i.e., v/s ratio), and (c) making the v/s ratios equal among alternative approach lanes. Equation 31-46 is derived from this representation.

$$\frac{v_i}{s_i} = \frac{\sum_{i=1}^{N_{th}} v_i}{\sum_{i=1}^{N_{th}} s_i}$$

Equation 31-46

where

v_i = demand flow rate in lane i (veh/h/ln),

s_i = saturation flow rate in lane i (veh/h/ln), and

N_{th} = number of through lanes (shared or exclusive) (ln).

The “equalization of flow ratios” principle has been embodied in the HCM since the 1985 edition. Specifically, it has been used to derive the equation for estimating the proportion of left-turning vehicles in a shared lane P_L .

During field observations of various intersection approaches, it was noted that the principle overestimated the effect of turning vehicles in shared lanes for very low and for very high approach flow-rate conditions (3). Under low flow-rate conditions, it was rationalized that through drivers are not motivated to change lanes because the frequency of turns is very low and the threat of delay is negligible. Under high flow-rate conditions, it was rationalized that through drivers do not have an opportunity to change lanes because of the lack of adequate gaps in the outside lane. The field observations also indicated that most lane choice decisions (and related lane changes) for through drivers tended to occur upstream of the intersection, before deceleration occurs.

As a result of these field observations (3), the model was extended to include the probability of a lane change. The probability of a lane change represents the joint probability of there being motivation (i.e., moderate to high flow rates) and opportunity (i.e., adequate lane-change gaps). A variable that is common to each probability distribution is the ratio of the approach flow rate to the maximum flow rate that would allow any lane changes. This maximum flow rate is the rate corresponding to the minimum headway considered acceptable for a lane change (i.e., about 3.7 s) (4). Exhibit 31-5 illustrates the modeled relationship between lane change probability and the flow ratio in the traffic lanes upstream of the intersection, before deceleration occurs (3).

Exhibit 31-5
Probability of a Lane Change

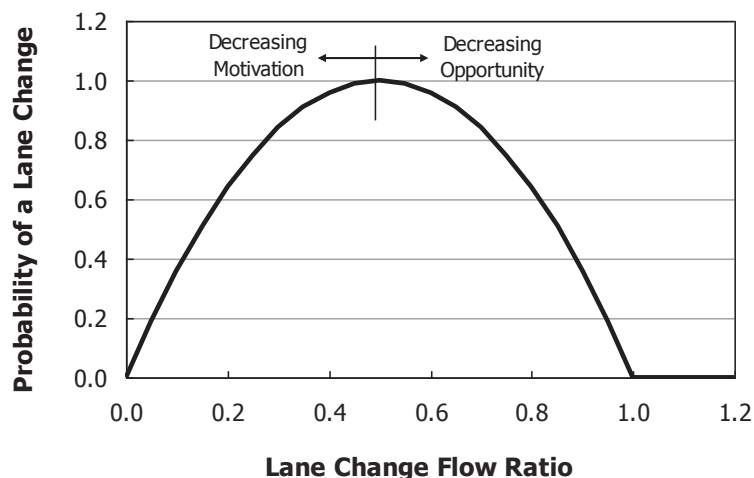

Procedure

The procedure described in this subsection is generalized so it can be applied to any signalized intersection approach with any combination of exclusive turn lanes, shared lanes, and exclusive through lanes. At least one shared lane must be present, and the approach must have two or more lanes (or bays) serving two or more traffic movements. This type of generalized formulation is attractive because of its flexibility; however, the trade-off is that the calculation process is iterative. If a closed-form solution is desired, then one would likely have to be uniquely derived for each lane assignment combination.

The procedure is described in the following steps. Input variables used in the procedure are identified in the following list and are shown in Exhibit 31-6:

- N_l = number of lanes in exclusive left-turn lane group (ln),
- N_{sl} = number of lanes in shared left-turn and through lane group (ln),
- N_t = number of lanes in exclusive through lane group (ln),
- N_{sr} = number of lanes in shared right-turn and through lane group (ln),
- N_r = number of lanes in exclusive right-turn lane group (ln),
- N_{lr} = number of lanes in shared left- and right-turn lane group (ln),
- v_{lt} = left-turn demand flow rate (veh/h),
- v_{th} = through demand flow rate (veh/h),
- v_{rt} = right-turn demand flow rate (veh/h),
- v_l = demand flow rate in exclusive left-turn lane group (veh/h/ln),
- v_{sl} = demand flow rate in shared left-turn and through lane group (veh/h),
- v_t = demand flow rate in exclusive through lane group (veh/h/ln),
- v_{sr} = demand flow rate in shared right-turn and through lane group (veh/h),
- v_r = demand flow rate in exclusive right-turn lane group (veh/h/ln),
- v_{lr} = demand flow rate in shared left- and right-turn lane group (veh/h),

- $v_{sl,lt}$ = left-turn flow rate in shared lane group (veh/h/lane),
- $v_{sr,rt}$ = right-turn flow rate in shared lane group (veh/h/lane),
- s_l = saturation flow rate in exclusive left-turn lane group with permitted operation (veh/h/lane),
- s_{sl} = saturation flow rate in shared left-turn and through lane group with permitted operation (veh/h/lane),
- s_t = saturation flow rate in exclusive through lane group (veh/h/lane),
- s_{sr} = saturation flow rate in shared right-turn and through lane group with permitted operation (veh/h/lane),
- s_r = saturation flow rate in exclusive right-turn lane group with permitted operation (veh/h/lane),
- s_{lr} = saturation flow rate in shared left- and right-turn lane group (veh/h/lane),
- s_{th} = saturation flow rate of an exclusive through lane (= base saturation flow rate adjusted for lane width, heavy vehicles, grade, parking, buses, area type, work zone presence, downstream lane blockage, and spillback) (veh/h/lane),
- g_p = effective green time for permitted left-turn operation (s),
- g_f = time before the first left-turning vehicle arrives and blocks the shared lane (s), and
- g_u = duration of permitted left-turn green time that is not blocked by an opposing queue (s).

Each shared-lane lane group has one lane (i.e., $N_{sl} = 1$, $N_{sr} = 1$, and $N_{lr} = 1$). Procedures for calculating g_p , g_f , and g_u are provided in Section 3.

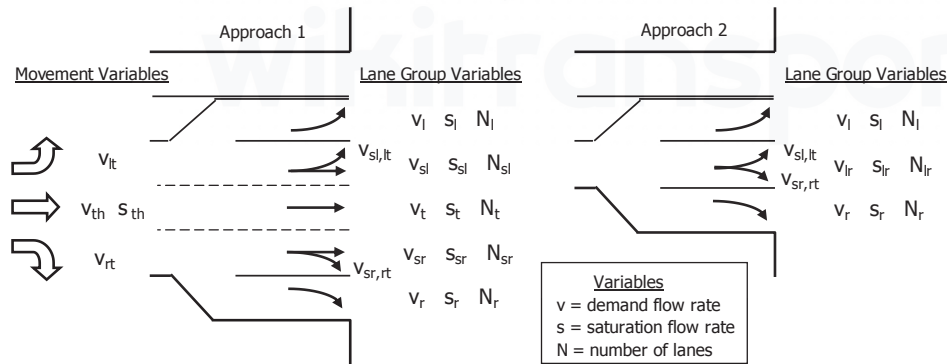

Exhibit 31-6
Input Variables for Lane Group Flow Rate Procedure

A. Compute Modified Through-Car Equivalent

Three modified through-car equivalent factors are computed for the left-turn movement. These factors are computed with Equation 31-47 through Equation 31-51.

$$E_{L,m} = (E_L - 1)P_{lc} + 1$$

Equation 31-47

Equation 31-48

$$E_{L1,m} = \left(\frac{E_{L1}}{f_{Lpb}} - 1 \right) P_{lc} + 1$$

Equation 31-49

$$E_{L2,m} = \left(\frac{E_{L2}}{f_{Lpb}} - 1 \right) P_{lc} + 1$$

with

Equation 31-50

$$P_{lc} = 1 - \left(\left[2 \frac{v_{app}}{s_{lc}} \right] - 1 \right)^2 \geq 0.0$$

Equation 31-51

$$v_{app} = \frac{v_{lt} + v_{th} + v_{rt}}{N_{sl} + N_t + N_{sr}}$$

where

$E_{L,m}$ = modified through-car equivalent for a protected left-turning vehicle,

$E_{L1,m}$ = modified through-car equivalent for a permitted left-turning vehicle,

E_L = equivalent number of through cars for a protected left-turning vehicle (= 1.05),

E_{L1} = equivalent number of through cars for a permitted left-turning vehicle,

$E_{L2,m}$ = modified through-car equivalent for a permitted left-turning vehicle when opposed by a queue on a single-lane approach,

E_{L2} = equivalent number of through cars for a permitted left-turning vehicle when opposed by a queue on a single-lane approach,

f_{Lpb} = pedestrian adjustment factor for left-turn groups,

P_{lc} = probability of a lane change among the approach through lanes,

v_{app} = average demand flow rate per through lane (upstream of any turn bays on the approach) (veh/h/ln),

s_{lc} = maximum flow rate at which a lane change can occur = 3,600/ t_{lc} (veh/h/ln), and

t_{lc} = critical merge headway = 3.7 (s).

The factor obtained from Equation 31-49 is applicable when permitted left-turning vehicles are opposed by a queue on a single-lane approach. Equations for calculating E_{L1} and E_{L2} are provided in Section 3. A procedure for calculating f_{Lpb} is provided later in this section.

If the approach has a shared left- and right-turn lane (as shown in Approach 2 in Exhibit 31-6), then Equation 31-52 is used to compute the average demand flow rate per lane (with $N_{lr} = 1.0$).

Equation 31-52

$$v_{app} = (v_{lt} + v_{rt})/N_{lr}$$

The modified through-car equivalent for permitted right-turning vehicles is computed with Equation 31-53.

Equation 31-53

$$E_{R,m} = \left(\frac{E_R}{f_{Rpb}} - 1 \right) P_{lc} + 1$$

where $E_{R,m}$ is the modified through-car equivalent for a protected right-turning vehicle, f_{Rpb} is the pedestrian–bicycle adjustment factor for right-turn groups, E_R is the equivalent number of through cars for a protected right-turning vehicle (= 1.18), and all other variables are as previously defined.

A procedure for calculating f_{Rpb} is provided later in this section.

If the opposing approach has two lanes serving through vehicles and the inside lane serves through and left-turn vehicles, then Equation 31-54 is used to compute the adjusted duration of permitted left-turn green time that is not blocked by an opposing queue g_u^* . This variable is then used in Equation 31-59 in replacement of the variable g_u . This adjustment is intended to reflect the occasional hesitancy of drivers to shift from the inside lane to the outside lane during higher-volume conditions for this approach-lane geometry. In all other cases of opposing approach-lane geometry, the variable g_u^* is not computed and Equation 31-59 is used as described in the text.

$$g_u^* = g_u + (g_{diff} \times P_{lc})$$

Equation 31-54

where

g_u^* = adjusted duration of permitted left-turn green time that is not blocked by an opposing queue (s), and

g_{diff} = supplemental service time (s).

Equation 31-107 in Section 3 can be used to calculate g_{diff} .

B. Estimate Shared-Lane Lane Group Flow Rate

The procedure to estimate the shared-lane lane group flow rate requires an initial estimate of the demand flow rate for each traffic movement in each shared-lane lane group on the subject approach. For the shared lane serving left-turn and through vehicles, the left-turn flow rate in the shared lane $v_{sl,lt}$ is initially estimated as 0.0 veh/h, and the total lane group flow rate v_{sl} is estimated as equal to the average flow rate per through lane v_{app} . For the shared lane serving right-turn vehicles, the right-turn flow rate in the shared lane $v_{sr,rt}$ is estimated as 0.0 veh/h, and the total lane group flow rate v_{sr} is estimated as equal to the average flow rate per through lane v_{app} . These estimates are updated in a subsequent step.

C. Compute Exclusive Lane-Group Flow Rate

The demand flow rate in the exclusive left-turn lane group v_l is computed with Equation 31-55, where all variables are as previously defined.

$$v_l = \frac{v_{lt} - v_{sl,lt}}{N_l} \geq 0.0$$

Equation 31-55

A similar calculation is completed to estimate the demand flow rate in the exclusive right-turn lane group v_r . The flow rate in the exclusive through lane group is then computed with Equation 31-56.

$$v_t = \frac{v_{th} - (v_{sl} - v_{sl,lt}) - (v_{sr} - v_{sr,rt})}{N_t} \geq 0.0$$

Equation 31-56

D. Compute Proportion of Turns in Shared-Lane Lane Groups

The proportion of left-turning vehicles in the shared left-turn and through lane is computed with Equation 31-57.

Equation 31-57

$$P_L = \frac{v_{sl,lt}}{v_{sl}} \leq 1.0$$

where P_L is the proportion of left-turning vehicles in the shared lane. Substitution of $v_{sr,rt}$ for $v_{sl,lt}$ and v_{sr} for v_{sl} in Equation 31-57 yields an estimate of the proportion of right-turning vehicles in the shared lane P_R .

The proportion of left-turning vehicles in the shared left- and right-turn lane is computed with Equation 31-58.

Equation 31-58

$$P_L = \frac{v_{sl,lt}}{v_{lr}} \leq 1.0$$

Substituting $v_{sr,rt}$ for $v_{sl,lt}$ in Equation 31-58 yields an estimate of the proportion of right-turning vehicles in the shared lane P_R .

E. Compute Lane Group Saturation Flow Rate

The saturation flow rate for the lane group shared by the left-turn and through movements is computed by using Equation 31-59 with Equation 31-60.

Equation 31-59

$$s_{sl} = \frac{s_{th}}{g_p} \left(g_f + \frac{g_{diff}}{1 + P_L[E_{L2,m} - 1]} + \frac{\min[g_p - g_f, g_u]}{1 + P_L[E_{L1,m} - 1]} + \frac{3,600 n_s^* f_{ms} f_{sp}}{s_{th}} \right)$$

with

Equation 31-60

$$n_s^* = \begin{cases} \frac{P_L}{1 - P_L} (1 - P_L^{n_s}) & \text{if } P_L < 0.999 \\ n_s P_L & \text{if } P_L \geq 0.999 \end{cases}$$

where g_{diff} is the supplemental service time (s), n_s^* is the expected number of sneakers per cycle in a shared left-turn lane, f_{ms} is the adjustment factor for downstream lane blockage, f_{sp} is the adjustment factor for sustained spillback, and all other variables are as previously defined.

Equation 31-107 in Section 3 can be used to calculate g_{diff} .

Equation 31-61 is used to compute the saturation flow rate in a shared right-turn and through lane group s_{sr} .

Equation 31-61

$$s_{sr} = \frac{s_{th}}{1 + P_R(E_{R,m} - 1)}$$

where P_R is the proportion of right-turning vehicles in the shared lane (decimal).

The saturation flow rate for the lane group serving left-turning vehicles in an exclusive lane s_l is computed with Equation 31-59, with $P_L = 1.0$, $g_{diff} = 0.0$, $g_f = 0.0$, and s_{th} replaced by s_{lt} (see Equation 31-112). Similarly, the saturation flow rate in an exclusive right-turn lane group s_r is computed with Equation 31-61, with $P_R = 1.0$.

The saturation flow rate for the lane group serving through vehicles in an exclusive lane is computed with Equation 31-62.

$$s_t = s_{th} f_s$$

where f_s is the adjustment factor for all lanes serving through vehicles on an approach with a shared left-turn and through lane group (= 1.0 if $N_{sl} = 0$; 0.91 otherwise).

The saturation flow rate for the shared left- and right-turn lane is computed with Equation 31-63.

$$s_{tr} = \frac{s_{th}}{1 + P_L(E_{L,m} - 1) + P_R(E_{R,m} - 1)}$$

Equation 31-62
Equation 31-63

F. Compute Flow Ratio

The flow ratio for the subject intersection approach is computed with Equation 31-64.

$$y^* = \frac{v_l N_l + v_{sl} N_{sl} + v_t N_t + v_{sr} N_{sr} + v_r N_r + v_{lr} N_{lr}}{s_l N_l + s_{sl} N_{sl} + s_t N_t + s_{sr} N_{sr} + s_r N_r + s_{lr} N_{lr}}$$

Equation 31-64

where y^* is the flow ratio for the approach. If a shared left- and right-turn lane exists on the subject approach, then $N_{sl} = 0$, $N_t = 0$, $N_{sr} = 0$, and $N_{lr} = 1$; otherwise, $N_{sl} = 1$, $N_t \geq 0$, $N_{sr} = 1$, and $N_{lr} = 0$.

G. Compute Revised Lane Group Flow Rate

The flow ratio from Step F is used to compute the demand flow rate in the exclusive left-turn lane group with Equation 31-65.

$$v_l = s_l y^*$$

Equation 31-65

In a similar manner, the demand flow rate for the other lane groups is estimated by multiplying the flow ratio y^* by the corresponding lane group saturation flow rate.

H. Compute Turn Movement Flow Rate in Shared-Lane Lane Groups

The left-turn demand flow rate in the shared lane group is computed with Equation 31-66.

$$v_{sl,lt} = v_{lt} - v_l \geq 0.0$$

Equation 31-66

Equation 31-66 can be used to compute the right-turn demand flow rate in the shared lane group by substituting $v_{sr,rt}$ for $v_{sl,lt}$, v_{rt} for v_{lt} , and v_r for v_l .

The demand flow rate in each shared-lane lane group is now compared with the rate estimated in Step B. If they differ by less than 0.1 veh/h, then the procedure is complete and the flow rates estimated in Steps G and H represent the best estimate of the flow rate for each lane group.

If there is disagreement between the lane group demand flow rates, then the calculations are repeated, starting with Step C. However, for this iteration, the flow rates computed in Steps G and H are used in the new calculation sequence. The calculations are complete when the flow rates used at the start of Step C differ from those obtained in Step H by less than 0.1 veh/h.

PRETIMED PHASE DURATION

The design of a pretimed timing plan can be a complex and iterative process that is generally carried out with the assistance of software. Several software products are available for this purpose. This subsection describes various strategies for pretimed signal-timing design and provides a procedure for implementing one of these strategies.

Design Strategies

Several aspects of signal-timing design, such as the choice of the timing strategy, are beyond the scope of this manual. Three basic strategies are commonly used for pretimed signals.

One strategy is to equalize the volume-to-capacity ratios for critical lane groups. It is the simplest strategy and the only one that can be calculated without excessive iteration. Under this strategy, the green time is allocated among the various signal phases in proportion to the flow ratio of the critical lane group for each phase. This strategy is described briefly in the next subsection. It is also used in the planning-level analysis application described in Section 5.

A second strategy is to minimize the total delay to all vehicles. This strategy is generally proposed as the optimal solution to the signal-timing problem. Variations of this strategy often combine other performance measures (e.g., stop rate, fuel consumption) in the optimization function. Many signal-timing software products offer this optimization feature. Some products use a delay estimation procedure identical to that in the motorized vehicle methodology in Chapter 19, but other products use minor departures from it.

A third strategy is to equalize the level of service (LOS) for all critical lane groups. This strategy promotes a LOS on all approaches that is consistent with the overall intersection LOS. It improves on the first and second strategies because they tend to produce a higher delay per vehicle for the minor movements at the intersection (and therefore a less favorable LOS).

Determining Phase Duration on the Basis of Vehicle Demand

Signal timing based on equalization of the volume-to-capacity ratio is described in this subsection. Equation 31-67, Equation 31-68, and Equation 31-69 are used to estimate the cycle length and effective green time for each critical phase. Conversion to green interval duration follows by applying the appropriate lost-time increments.

Equation 31-67

$$X_c = \left(\frac{C}{C - L} \right) \sum_{i \in ci} y_{c,i}$$

Equation 31-68

$$C = \frac{L X_c}{X_c - \sum_{i \in ci} y_{c,i}}$$

Equation 31-69

$$g_i = \frac{v_i C}{N_i s_i X_i} = \left(\frac{v}{N s} \right)_i \left(\frac{C}{X_i} \right)$$

where

C = cycle length (s),

- L = cycle lost time (s),
 X_c = critical intersection volume-to-capacity ratio,
 $y_{c,i}$ = critical flow ratio for phase $i = v_i/(N s_i)$,
 ci = set of critical phases on the critical path,
 X_i = volume-to-capacity ratio for lane group i ,
 v_i = demand flow rate for lane group i (veh/h),
 N_i = number of lanes in lane group i (ln),
 s_i = saturation flow rate for lane group i (veh/h/ln), and
 g_i = effective green time for lane group i (s).

The summation term in each of these equations represents the summation of a specific variable for the set of critical phases. A critical phase is one phase of a set of phases that occurs in sequence whose combined flow ratio is the largest for the signal cycle.

Procedure

The following steps summarize the procedure for estimating the cycle length and effective green time for the critical phases:

1. Compute the flow ratio $[= v_i/(N s_i)]$ for each lane group and identify the critical flow ratio for each phase. When there are several lane groups on the approach and they are served during a common phase, then the lane group with the largest flow ratio represents the critical flow ratio for the phase. A procedure for identifying the critical phases and associated flow ratios is described in Section 4 of Chapter 19, Signalized Intersections.
2. If signal-system constraints do not dictate the cycle length, then estimate the minimum cycle length with Equation 31-68 by setting X_c equal to 1.0.
3. If signal-system constraints do not dictate the cycle length, then estimate the desired cycle length with Equation 31-68 by substituting a target volume-to-capacity ratio X_t for the critical ratio X_c . A value of X_t in the range of 0.80 to 0.90 is recommended for this purpose.
4. If signal-system constraints do not dictate the cycle length, then use the results of Steps 2 and 3 to select an appropriate cycle length for the signal. Otherwise, the cycle length is that dictated by the signal system.
5. Estimate the effective green time for each phase with Equation 31-69 and the target volume-to-capacity ratio.
6. Check the timing to ensure the effective green time and the lost time for each phase in a common ring sum to the cycle length.

Example Application

The procedure is illustrated by a sample calculation. Consider the intersection shown in Exhibit 31-7.

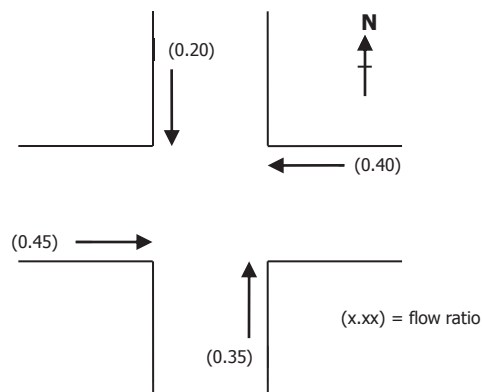
Exhibit 31-7
 Example Intersection

Phases 2 and 6 serve the eastbound and westbound approaches, respectively. Phases 4 and 8 serve the southbound and northbound approaches, respectively. One phase from each pair will represent the critical phase and dictate the duration of both phases. It is assumed the lost time for each phase equals the change period (i.e., the yellow change interval plus the red clearance interval). Thus, the lost time for each critical phase is 4 s, or 8 s for the cycle.

In this simple example, only one lane group is served on each approach, so the critical flow ratios can be identified by inspection of Exhibit 31-7. Specifically, the critical flow ratio for the east–west phases is that associated with the eastbound approach (i.e., Phase 2) at a value of 0.45. Similarly, the critical flow ratio for the north–south phases is that associated with the northbound approach (i.e., Phase 8).

The minimum cycle length that will avoid oversaturation is computed by Equation 31-68 with $X_c = 1.00$.

$$C(\text{minimum}) = \frac{8(1.0)}{1.0 - (0.45 + 0.35)} = \frac{8}{0.2} = 40 \text{ s}$$

A target volume-to-capacity ratio of 0.80 is used to estimate the target cycle length.

$$C = \frac{8(0.8)}{0.8 - (0.45 + 0.35)} = \frac{6.4}{0} = \text{infinity}$$

This computation indicates a critical volume-to-capacity ratio of 0.8 cannot be provided with the present demand levels at the intersection.

As a second trial estimate, a target volume-to-capacity ratio of 0.92 is selected and used to estimate the target cycle length.

$$C = \frac{8(0.92)}{0.92 - (0.45 + 0.35)} = 61 \text{ s}$$

The estimate is rounded to 60 s for practical application. Equation 31-67 is then used to estimate the critical volume-to-capacity ratio of 0.923 for the selected cycle length of 60 s.

With Equation 31-69, the effective green time is allocated so the volume-to-capacity ratio for each critical lane group is equal to the target volume-to-capacity ratio. Thus, for the example problem, the target volume-to-capacity ratio

for each phase is 0.923. The effective green times are computed with Equation 31-69. The results of the calculations are listed below:

$$\begin{aligned}g_2 &= 0.45(60/0.923) = 29.3 \text{ s} \\g_8 &= 0.35(60/0.923) = 22.7 \text{ s} \\g_2 + g_8 + L &= 29.3 + 22.7 + 8.0 = 60.0 \text{ s}\end{aligned}$$

The duration of the effective green interval for Phase 6 is the same as for Phase 2, given that they have the same phase lost time. Similarly, the effective green interval for Phase 4 is the same as for Phase 8.

Determining Phase Duration on the Basis of Pedestrian Considerations

Two pedestrian considerations are addressed in this subsection as they relate to pretimed phase duration. One consideration addresses the time a pedestrian needs to perceive the signal indication and traverse the crosswalk. A second consideration addresses the time needed to serve cyclic pedestrian demand. When available, local guidelines or practice should be used to establish phase duration on the basis of pedestrian considerations.

A minimum green interval duration that allows a pedestrian to perceive the indication and traverse the crosswalk can be computed with Equation 31-70.

$$G_{p,min} = t_{pr} + \frac{L_{cc}}{S_p} - Y - R_c$$

Equation 31-70

where

$G_{p,min}$ = minimum green interval duration based on pedestrian crossing time (s),

t_{pr} = pedestrian perception of signal indication and curb departure time = 7.0 (s),

L_{cc} = curb-to-curb crossing distance (ft),

S_p = pedestrian walking speed = 3.5 (ft/s),

Y = yellow change interval (s), and

R_c = red clearance interval (s).

The variable t_{pr} in this equation represents the time pedestrians need to perceive the start of the phase and depart from the curb. A value of 7.0 s represents a conservatively long value that is adequate for most pedestrian crossing conditions. The variable S_p represents the pedestrian walking speed in a crosswalk. A value of 3.5 ft/s represents a conservatively slow value that most pedestrians will exceed.

If a permitted or protected-permitted left-turn operation is used for the left-turn movement that crosses the subject crosswalk, then the subtraction of the yellow change interval and the red clearance interval in Equation 31-70 may cause some conflict between pedestrians and left-turning vehicles. If this conflict can occur, then the minimum green interval duration should be computed as $G_{p,min} = t_{pr} + (L_{cc}/S_p)$.

The second pedestrian consideration in timing design is the time required to serve pedestrian demand. The green interval duration should equal or exceed this time to ensure pedestrian demand is served each cycle. The time needed to serve this demand is computed with either Equation 31-71 or Equation 31-72, along with Equation 31-73.

If the crosswalk width W is greater than 10 ft, then

Equation 31-71

$$t_{ps} = 3.2 + \frac{L_{cc}}{S_p} + 2.7 \frac{N_{ped}}{W}$$

If the crosswalk width W is less than or equal to 10 ft, then

Equation 31-72

$$t_{ps} = 3.2 + \frac{L_{cc}}{S_p} + 0.27 N_{ped}$$

with

Equation 31-73

$$N_{ped} = \frac{v_{ped,i}}{3,600} C$$

where

t_{ps} = pedestrian service time (s),

W = effective width of crosswalk (ft),

$v_{ped,i}$ = pedestrian flow rate in the subject crossing for travel direction i (p/h),
and

N_{ped} = number of pedestrians crossing during an interval (p).

Equation 31-73 assumes pedestrians always cross at the start of the phase. Thus, it yields a conservatively large estimate of N_{ped} because some pedestrians arrive and cross during the green indication.

Equation 31-73 is specific to the pedestrian flow rate in one direction of travel along the subject crosswalk. If the pedestrian flow rate varies significantly during the analysis period for the crosswalk's two travel directions, then t_{ps} should be calculated for both travel directions, and the larger value should be used to estimate the green interval duration needed to serve pedestrian demand.

PEDESTRIAN AND BICYCLE ADJUSTMENT FACTORS

Exhibit 31-8 shows sample conflict zones where intersection users compete for space. This competition reduces the saturation flow rate of the turning vehicles. Its effect is quantified in the pedestrian and bicycle adjustment factors. This subsection describes a procedure for calculating these factors, which are used in the procedure for calculating the adjusted saturation flow rate that is described in Section 3 of Chapter 19.

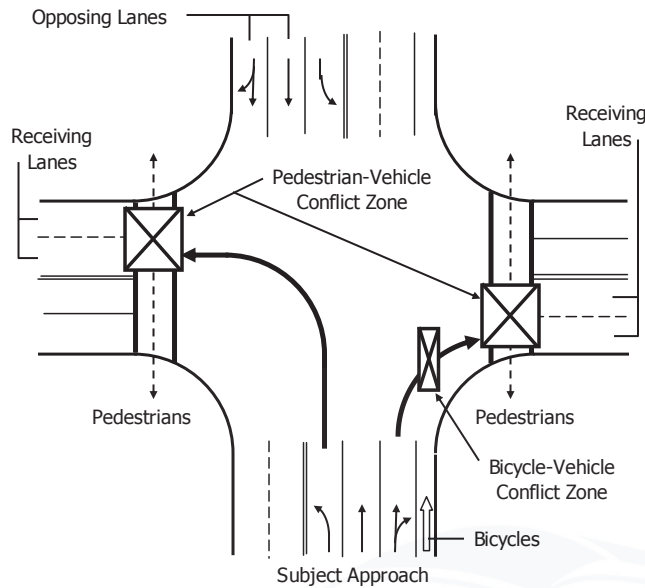

Exhibit 31-8
Conflict Zone Locations

This subsection consists of two subsections. The first subsection describes the procedure for computing (a) the pedestrian–bicycle adjustment factor for right-turn lane groups and (b) the pedestrian adjustment factor for left-turn lane groups from a one-way street. The second subsection describes the procedure for computing the pedestrian adjustment factor for left-turn groups served by permitted or protected-permitted operation.

The following guidance is used to determine the pedestrian adjustment factor for lane groups serving left-turn movements f_{Lpb} :

- If there are no conflicting pedestrians, then f_{Lpb} is equal to 1.0.
- If the lane group is on a two-way street and the protected mode or split phasing is used, then f_{Lpb} is equal to 1.0.
- If the lane group is on a one-way street, then the procedure described in the first subsection below is used to compute f_{Lpb} .
- If the lane group is on a two-way street and either the permitted mode or the protected-permitted mode is used, then the procedure described in the second subsection below is used to calculate f_{Lpb} .

The following guidance is used to determine the pedestrian–bicycle adjustment factor for lane groups serving right-turn movements f_{Rpb} :

- If there are no conflicting pedestrians or bicycles, then f_{Rpb} is equal to 1.0.
- If the protected mode is used, then f_{Rpb} is equal to 1.0.
- If the permitted mode or the protected-permitted mode is used, then the procedure described in the first subsection below is used to compute f_{Rpb} .

Right-Turn Movements and Left-Turn Movements from One-Way Street

A. Determine Pedestrian Flow Rate During Service

This procedure requires knowledge of the phase duration and cycle length. If these variables are not known and the intersection is pretimed, then they can be estimated by using the procedure described in the previous subsection titled Pretimed Phase Duration. If the intersection is actuated, then the average phase duration and cycle length can be computed by using the procedure described in the previous subsection titled Actuated Phase Duration.

The pedestrian flow rate during the pedestrian service time is computed with Equation 31-74.

Equation 31-74

$$v_{pedg} = v_{ped} \frac{C}{g_{ped}} \leq 5,000$$

where

v_{pedg} = pedestrian flow rate during the pedestrian service time (p/h),

v_{ped} = pedestrian flow rate in the subject crossing (walking in both directions) (p/h),

C = cycle length (s), and

g_{ped} = pedestrian service time (s).

If the phase providing service to pedestrians is actuated, has a pedestrian signal head, and rest-in-walk is not enabled, then the pedestrian service time is equal to the smaller of (a) the effective green time for the phase or (b) the sum of the walk and pedestrian clear settings [i.e., $g_{ped} = \min(g, Walk + PC)$]. Otherwise, the pedestrian service time can be assumed to equal the effective green time for the phase (i.e., $g_{ped} = g$).

B. Determine Average Pedestrian Occupancy

If the pedestrian flow rate during the pedestrian service time is 1,000 p/h or less, then the pedestrian occupancy is computed with Equation 31-75.

Equation 31-75

$$OCC_{pedg} = \frac{v_{pedg}}{2,000}$$

where OCC_{pedg} is the pedestrian occupancy.

If the pedestrian flow rate during the pedestrian service time exceeds 1,000 p/h, then Equation 31-76 is used.

Equation 31-76

$$OCC_{pedg} = 0.4 + \frac{v_{pedg}}{10,000} \leq 0.90$$

A practical upper limit on v_{pedg} of 5,000 p/h should be maintained when Equation 31-76 is used.

C. Determine Bicycle Flow Rate During Green

The bicycle flow rate during the green indication is computed with Equation 31-77.

Equation 31-77

$$v_{bicg} = v_{bic} \frac{C}{g} \leq 1,900$$

where

v_{bicg} = bicycle flow rate during the green indication (bicycles/h),

v_{bic} = bicycle flow rate (bicycles/h),

C = cycle length (s), and

g = effective green time (s).

D. Determine Average Bicycle Occupancy

The average bicycle occupancy is computed with Equation 31-78.

$$OCC_{bicg} = 0.02 + \frac{v_{bicg}}{2,700}$$

Equation 31-78

where OCC_{bicg} is the bicycle occupancy, and v_{bicg} is the bicycle flow rate during the green indication (bicycles/h).

A practical upper limit on v_{bicg} of 1,900 bicycles/h should be maintained when Equation 31-78 is used.

E. Determine Relevant Conflict Zone Occupancy

Equation 31-79 is used for right-turn movements with no bicycle interference or for left-turn movements from a one-way street. This equation is based on the assumptions that (a) pedestrian crossing activity takes place during the time period associated with g_{pedr} and (b) no crossing occurs during the green time period $g - g_{pedr}$ when this time period exists.

$$OCC_r = \frac{g_{ped}}{g} OCC_{pedg}$$

Equation 31-79

where OCC_r is the relevant conflict zone occupancy.

Alternatively, Equation 31-80 is used for right-turn movements with pedestrian and bicycle interference, with all variables as previously defined.

$$OCC_r = \left(\frac{g_{ped}}{g} OCC_{pedg} \right) + OCC_{bicg} - \left(\frac{g_{ped}}{g} OCC_{pedg} OCC_{bicg} \right)$$

Equation 31-80

F. Determine Unoccupied Time

If the number of cross-street receiving lanes is equal to the number of turn lanes, then turning vehicles will not be able to maneuver around pedestrians or bicycles. In this situation, the time the conflict zone is unoccupied is computed with Equation 31-81.

$$A_{pbT} = 1 - OCC_r$$

Equation 31-81

where A_{pbT} is the unoccupied time, and OCC_r is the relevant conflict zone occupancy.

Alternatively, if the number of cross-street receiving lanes exceeds the number of turn lanes, turning vehicles will more likely maneuver around pedestrians or bicycles. In this situation, the effect of pedestrians and bicycles on saturation flow is lower, and the time the conflict zone is unoccupied is computed with Equation 31-82.

$$A_{pbT} = 1 - 0.6 OCC_r$$

Equation 31-82

Either Equation 31-81 or Equation 31-82 is used to compute A_{pbT} . The choice of which equation to use should be based on careful consideration of the number of turn lanes and the number of receiving lanes. At some intersections, drivers may consistently and deliberately make illegal turns from an exclusive through lane. At other intersections, proper turning cannot be executed because the receiving lane is blocked by double-parked vehicles. For these reasons, the number of turn lanes and receiving lanes should be determined from field observation.

G. Determine Saturation Flow Rate Adjustment Factor

For permitted right-turn operation in an exclusive lane, Equation 31-83 is used to compute the pedestrian–bicycle adjustment factor.

Equation 31-83

$$f_{Rpb} = A_{pbT}$$

where f_{Rpb} is the pedestrian–bicycle adjustment factor for right-turn groups, and A_{pbT} is the unoccupied time.

For protected-permitted operation in an exclusive lane, the factor from Equation 31-83 is used to compute the adjusted saturation flow rate during the permitted period. The factor has a value of 1.0 when used to compute the adjusted saturation flow rate for the protected period.

For left-turn movements from a one-way street, Equation 31-84 is used to compute the pedestrian adjustment factor.

Equation 31-84

$$f_{Lpb} = A_{pbT}$$

where f_{Lpb} is the pedestrian adjustment factor for left-turn groups, and A_{pbT} is the unoccupied time.

Permitted and Protected-Permitted Left-Turn Movements

This subsection describes a procedure for computing the adjustment factor for left-turn movements on a two-way street that are operating in either the permitted mode or the protected-permitted mode. The calculations in this subsection supplement the procedure described in the previous subsection. The calculations described in Steps A and B in the previous subsection must be completed first (substitute the effective permitted green time g_p for g in Step A), after which the calculations described in this subsection are completed.

This procedure does not account for vehicle–bicycle conflict during the left-turn maneuver.

A. Compute Pedestrian Occupancy After Queue Clears

The pedestrian occupancy after the opposing queue clears is computed with Equation 31-85 or Equation 31-86. The opposing-queue service time g_q is computed as the effective permitted green time g_p less the duration of permitted left-turn green time that is not blocked by an opposing queue g_u (i.e., $g_q = g_p - g_u$).

If $g_q < g_{ped}$, then

Equation 31-85

$$OCC_{pedu} = OCC_{pedg} \left(1 - \frac{0.5 g_q}{g_{ped}} \right)$$

otherwise

$$OCC_{pedu} = 0.0$$

where OCC_{pedu} is the pedestrian occupancy after the opposing queue clears, g_q is the opposing-queue service time ($= g_s$ for the opposing movement) (s), and all other variables are as previously defined.

If the opposing-queue service time g_q equals or exceeds the pedestrian service time g_{ped} , then the opposing queue consumes the entire pedestrian service time.

B. Determine Relevant Conflict Zone Occupancy

After the opposing queue clears, left-turning vehicles complete their maneuvers on the basis of accepted gap availability in the opposing traffic stream. Relevant conflict zone occupancy is a function of the probability of accepted gap availability and pedestrian occupancy. It is computed with Equation 31-87.

$$OCC_r = \frac{g_{ped} - g_q}{g_p - g_q} (OCC_{pedu}) e^{-5.00 v_o / 3,600}$$

where v_o is the opposing demand flow rate (veh/h), g_p is the effective green time for permitted left-turn operation (s), and all other variables are as previously defined.

The opposing demand flow rate v_o is determined to be one of two cases. In Case 1, v_o equals the sum of the opposing through and right-turn volumes. In Case 2, v_o equals the opposing through volume. Case 2 applies when there is a through movement on the opposing approach and one of the following conditions applies: (a) there is an exclusive right-turn lane on the opposing approach and the analyst optionally indicates that this lane does not influence the left-turn drivers' gap acceptance, or (b) there is no right-turn movement on the opposing approach. Case 1 applies whenever Case 2 does not apply.

When an exclusive right-turn lane exists on the opposing approach, the default condition is to assume this lane influences the subject left-turn drivers' gap acceptance. The determination that the exclusive right-turn lane does not influence gap acceptance should be based on knowledge of local driver behavior, traffic conditions, and intersection geometry.

C. Determine Unoccupied Time

Either Equation 31-81 or Equation 31-82 from the previous subsection (i.e., Step F above) is used to compute A_{pbT} . The choice of which equation to use should be based on a consideration of the number of left-turn lanes and the number of receiving lanes.

D. Determine Saturation Flow Rate Adjustment Factor

Equation 31-88 is used to compute the pedestrian adjustment factor f_{Lpb} from A_{pbT} , the unoccupied time.

$$f_{Lpb} = A_{pbT}$$

Equation 31-86

Equation 31-87

Equation 31-88

WORK ZONE PRESENCE ADJUSTMENT FACTOR

The procedure described in this subsection can be used to evaluate signalized intersection operation when a work zone is present on the intersection approach. The work zone is considered to be on the intersection approach if some (or all) of the work zone is located between the stop line and a point 250 ft upstream of the stop line. The work zone may be located on the shoulder, or it may include the closure of one or more lanes. An intersection with a work zone located on the eastbound approach is shown in Exhibit 31-9.

Exhibit 31-9
Work Zone on an Intersection Approach

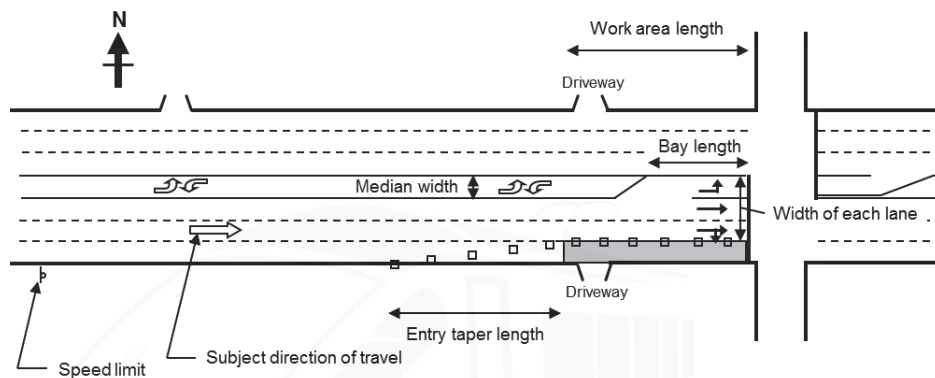

Required Input Data

The input data that are needed to estimate the effect of work zone presence on saturation flow rate are listed in Exhibit 31-10. The two data elements listed are described in this subsection. The contents of Exhibit 31-10 are in addition to those listed in Exhibit 19-11.

Exhibit 31-10
Geometric Design Input Data Requirements for Work Zones

Input Data Element and Units	Basis
Number of lanes open on the approach in the work zone (In)	Approach
Approach lane width during work zone (ft)	Approach

Note: Approach = one value or condition for the intersection approach.

Number of Lanes Open on the Approach in the Work Zone

The number of lanes open on the approach in the work zone represents the count of left-turn and through lanes that are open during work zone presence. The count does not include any exclusive right-turn lanes that may exist. The count is taken in the work zone (not upstream or downstream of the work zone). If the number of lanes in the work zone varies, then the smallest number of lanes provided to motorists is used for this input variable.

Approach Lane Width During Work Zone

The approach lane width represents the total width of all open left-turn, through, and right-turn lanes on the intersection approach when the work zone is present.

Computational Steps

The saturation flow rate adjustment factor for the case in which a work zone is located at the intersection can be computed by using Equation 31-89 with Equation 31-90 and Equation 31-91.

$$f_{wz} = 0.858 \times f_{wid} \times f_{reduce} \leq 1.0$$

Equation 31-89

with

$$f_{wid} = \frac{1}{1 - 0.0057 (a_w - 12)}$$

Equation 31-90

$$f_{reduce} = \frac{1}{1 + 0.0402 (n_o - n_{wz})}$$

Equation 31-91

where

f_{wz} = adjustment factor for work zone presence at the intersection,

f_{wid} = adjustment factor for approach width,

f_{reduce} = adjustment factor for reducing lanes during work zone presence,

a_w = approach lane width during work zone (= total width of all open left-turn, through, and right-turn lanes) (ft),

n_o = number of left-turn and through lanes open during normal operation (ln), and

n_{wz} = number of left-turn and through lanes open during work zone presence (ln).

This factor is computed during Step 4, Determine Adjusted Saturation Flow Rate, of the motorized vehicle methodology in Chapter 19, Signalized Intersections. One value is computed for (and is applicable to) all lane groups on the subject intersection approach.

wikitransport

3. QUEUE ACCUMULATION POLYGON

This section describes a procedure for using the queue accumulation polygon (QAP) to estimate delay. The section consists of three subsections. The first subsection provides a review of concepts related to the QAP. The second subsection describes a general procedure for developing the QAP, and the third subsection extends the general procedure to the evaluation of left-turn lane groups.

The discussion in this section describes basic principles for developing polygons for selected types of lane assignment, lane grouping, left-turn operation, and phase sequence. The analyst is referred to the computational engine for specific calculation details, especially as they relate to assignments, groupings, left-turn operations, and phase sequences not addressed in this section. This engine is described in Section 7.

CONCEPTS

The QAP is a graphic tool for describing the deterministic relationship between vehicle arrivals, departures, queue service time, and delay. The QAP defines the queue size for a traffic movement as a function of time during the cycle. The shape of the polygon is defined by the following factors: arrival flow rate during the effective red and green intervals, saturation flow rate associated with each movement in the lane group, signal indication status, left-turn operation mode, and phase sequence. Once constructed, the polygon can be used to compute the queue service time, capacity, and uniform delay for the corresponding lane group.

A QAP is shown in Exhibit 31-11. The variables shown in the exhibit are defined in the following list:

$$r = \text{effective red time} = C - g \text{ (s)},$$

$$g = \text{effective green time (s)},$$

$$C = \text{cycle length (s)},$$

$$g_s = \text{queue service time} = Q_r / (s - q_g) \text{ (s)},$$

$$g_e = \text{green extension time (s)},$$

$$q = \text{arrival flow rate} = v / 3,600 \text{ (veh/s)},$$

$$v = \text{demand flow rate (veh/h)},$$

$$q_r = \text{arrival flow rate during the effective red time} = (1 - P) q C / r \text{ (veh/s)},$$

$$q_g = \text{arrival flow rate during the effective green time} = P q C / g \text{ (veh/s)},$$

$$Q_r = \text{queue size at the end of the effective red time} = q_r r \text{ (veh)},$$

$$P = \text{proportion of vehicles arriving during the green indication (decimal)},$$

and

$$s = \text{adjusted saturation flow rate (veh/h/ln)}.$$

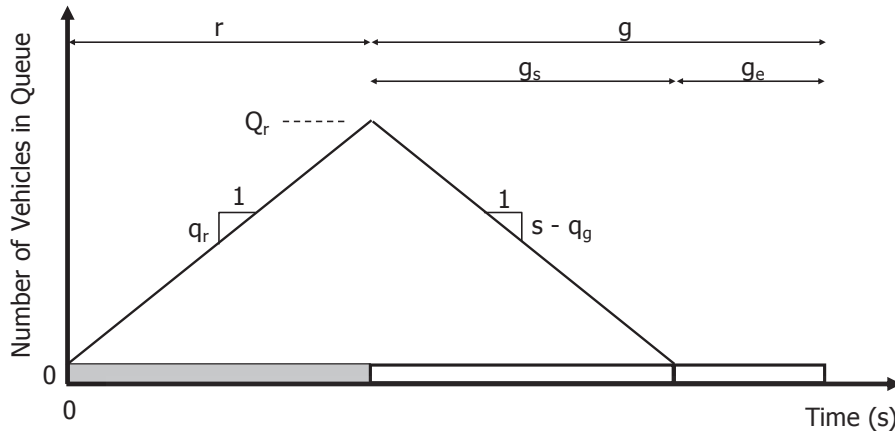

Exhibit 31-11
Queue Accumulation Polygon
for Protected Movements

In application, all flow rate variables are converted to common units of vehicles per second per lane. The presentation in this section is based on these units for q and s .

The polygon in Exhibit 31-11 applies to either a through lane group or a left- or right-turn lane group with exclusive lanes operating with the protected mode. Other polygon shapes are possible, depending on whether the lane group includes a shared lane and whether the lane group serves a permitted (or protected-permitted) left-turn movement. In general, a unique polygon shape will be dictated by each combination of left-turn operational mode (i.e., permitted, protected, or protected-permitted) and phase sequence (i.e., lead, lag, or split). A general procedure for constructing these polygons is described in the next subsection.

GENERAL QAP CONSTRUCTION PROCEDURE

This subsection describes a general procedure for constructing a QAP for a lane group at a signalized intersection. It is directly applicable to left-turn lane groups that have exclusive lanes and protected operation, through lane groups with exclusive lanes, and right-turn lane groups with exclusive lanes. Variations that extend this procedure to turn lane groups with shared lanes, permitted operation, or protected-permitted operation are described in the next subsection.

The construction of a QAP is based on identification of flow rates and service times during the average signal cycle. These rates and times define periods of queue growth, queue service, and service upon arrival. As shown in Exhibit 31-11, the rates and times define queue size as it varies during the cycle. The resulting polygon formed by the queue size profile can be decomposed into a series of trapezoid or triangle shapes, with each shape having a known time interval. Collectively, the areas of the individual shapes can be added to equal the area of the polygon, and the time intervals can be added to equal the cycle length.

The QAP calculation sequence follows the order of interval occurrence over time, and the results can be recorded graphically (as in Exhibit 31-11) or in a tabular manner (i.e., row by row, where each row represents one time interval). A time interval is defined to begin and end at points when either the departure rate or the arrival rate changes. For the duration of the interval, these rates are assumed to be constant.

The following text outlines the calculation sequence used to construct a QAP for a specified lane group. The sequence is repeated for each lane group at the intersection, with the through lane groups evaluated first so the saturation flow rate of permitted left-turn lane groups can be based on the known queue service time for the opposing traffic movements.

1. The QAP calculations for a given lane group start with the end of the effective green period for the phase serving the subject lane group in a protected manner. The initial queue Q_i is assumed to equal 0.0 vehicles.
2. Determine the points in the cycle when the arrival flow rate or the discharge rate changes. The arrival rate may change because of platoons formed in response to an upstream signal, so it is expressed in terms of the arrival rate during green q_g and during red q_r . The discharge rate may change because of the start or end of effective green, a change in the saturation flow rate, the depletion of the subject queue, the depletion of the opposing queue, or the departure of left-turn vehicles as sneakers.
3. For the time interval between the points identified in Step 2, number each interval and compute its duration. Next, identify the arrival rate and discharge rate associated with the interval. Finally, confirm that the sum of all interval durations equals the cycle length.
4. Calculate the capacity of each interval for which there is some discharge, including sneakers when applicable. The sum of these capacities equals the total lane group capacity. Calculate the demand volume for each interval for which there are some arrivals. The sum of these volumes equals the total lane group volume.
5. Calculate the volume-to-capacity ratio X for the lane group by dividing the lane group's total volume by its total capacity. If the volume-to-capacity ratio exceeds 1.0, then calculate the adjusted arrival flow rate q' for each interval by dividing the original flow rate q by X (i.e., $q' = q/X$).
6. Calculate the queue at the end of interval i with Equation 31-92.

Equation 31-92

$$Q_i = Q_{i-1} - \left(\frac{s}{3,600} - \frac{q}{N} \right) t_{d,i} \geq 0.0$$

where Q_i is the queue size at the end of interval i (veh), $t_{d,i}$ is the duration of time interval i during which the arrival flow rate and saturation flow rate are constant (s), and all other variables are as previously defined.

7. If the queue at the end of interval i equals 0.0 vehicles, then compute the duration of the trapezoid or triangle with Equation 31-93. The subject interval should be divided into two intervals, with the first interval having a duration of $t_{t,i}$ and the second interval having a duration of $t_{d,i} - t_{t,i}$. The second interval has starting and ending queues equal to 0.0 vehicles.

Equation 31-93

$$t_{t,i} = \min(t_{d,i}, Q_{i-1}/w_q)$$

where $t_{t,i}$ is the duration of trapezoid or triangle in interval i (s), w_q is the queue change rate (= discharge rate minus arrival rate) (veh/s), and all other variables are as previously defined.

8. Steps 6 and 7 are repeated for each interval in the cycle.

9. When all intervals are completed, the assumption of a zero starting queue (made in Step 1) is checked. The queue size computed for the last interval should always equal the initially assumed value. If this is not the case, then Steps 6 through 8 are repeated by using the ending queue size of the last interval as the starting queue size for the first interval.
10. When all intervals have been evaluated and the starting and ending queue sizes are equal, then the uniform delay can be calculated. This calculation starts with computing the area of each trapezoid or triangle. These areas are then added to determine the total delay. Finally, the total delay is divided by the number of arrivals per cycle to produce uniform delay. Equations for calculating uniform delay by using the QAP are described in Step 7 of the next subsection.

QAP CONSTRUCTION PROCEDURE FOR SELECTED LANE GROUPS

This subsection describes a seven-step procedure for constructing a QAP for selected lane groups. The focus is on left-turn movements in lane groups with shared lanes, permitted operation, or protected-permitted operation. However, there is some discussion of other lane groups, lane assignments, and operation. The procedure described in this subsection represents an extension of the general procedure described in the previous subsection.

Step 1. Determine Permitted Green Time

This step applies when the subject left-turn movement is served by using the permitted mode or the protected-permitted mode. Two effective green times are computed. One is the effective green time for permitted left-turn operation g_p . This green time occurs during the period when the adjacent and opposing through movements both have a circular green indication (after adjustment for lost time).

The other effective green time represents the duration of permitted left-turn green time that is not blocked by an opposing queue g_u . This green time represents the time during the effective green time for permitted left-turn operation g_p that is not used to serve the opposing queue. This time is available to the subject left-turn movement to filter through the conflicting traffic stream.

Exhibit 31-12 provides equations for computing the unblocked permitted green time for left-turn Movement 1 (see Exhibit 19-1) when Dallas left-turn phasing is *not* used. Similar equations can be derived for the other left-turn movements or when Dallas phasing is used. The variables defined in this exhibit are provided in the following list:

g_u = duration of permitted left-turn green time that is not blocked by an opposing queue (s),

G_U = displayed green interval corresponding to g_u (s),

e = extension of effective green = 2.0 (s),

l_1 = start-up lost time = 2.0 (s),

G_q = displayed green interval corresponding to g_q (s),

Exhibit 31-12
Unblocked Permitted Green Time

D_p = phase duration (s),
 R_c = red clearance interval (s),
 Y = yellow change interval (s), and
 g_q = opposing-queue service time (= g_s for the opposing movement) (s).

Phase Sequence (phase numbers shown in boxes)		Displayed Unblocked Permitted Green Time $G_{U1}(s)^a$	Permitted Start-Up Lost Time $I_{1,p}(s)^b$	Permitted Extension Time $e_p(s)^c$				
Lead- Lead	<table border="1"><tr><td>1</td><td>2</td></tr><tr><td>5</td><td>6</td></tr></table>	1	2	5	6	$G_{U1} = \min[D_{p1} + D_{p2} - D_{p5} - Y_6 - R_{c6}, G_{U1}^*]$ with $G_{U1}^* = D_{p2} - Y_6 - R_{c6} - G_{q2}$	$I_{1,1}^*$	e_1
	1	2						
5	6							
	<table border="1"><tr><td>1</td><td>2</td></tr><tr><td>5</td><td>6</td></tr></table>	1	2	5	6	$G_{U1} = D_{p2} - Y_6 - R_{c6} - G_{q2}$	$I_{1,1}^*$	e_1
1	2							
5	6							
Lead- Lag or Lead- Perm	<table border="1"><tr><td>1</td><td>2</td></tr><tr><td>6</td><td>5</td></tr></table>	1	2	6	5	$G_{U1} = D_{p6} - Y_6 - R_{c6} - D_{p1} - G_{q2}$	0.0	e_1
	1	2						
	6	5						
<table border="1"><tr><td>1</td><td>2</td></tr><tr><td>6</td><td>5</td></tr></table>	1	2	6	5	No permitted period	Not applicable	Not applicable	
1	2							
6	5							
<table border="1"><tr><td>1</td><td>2</td></tr><tr><td>6</td><td>6</td></tr></table>	1	2	6	6	$G_{U1} = D_{p6} - Y_6 - R_{c6} - D_{p1} - G_{q2}$	0.0	e_1	
1	2							
6	6							
Lag- Lead or Lag- Perm	<table border="1"><tr><td>2</td><td>1</td></tr><tr><td>5</td><td>6</td></tr></table>	2	1	5	6	No permitted period	Not applicable	Not applicable
	2	1						
	5	6						
<table border="1"><tr><td>2</td><td>1</td></tr><tr><td>5</td><td>6</td></tr></table>	2	1	5	6	$G_{U1} = D_{p2} - Y_2 - R_{c2} - \max[D_{p5}, G_{q2}]$	$I_{1,1}$	0.0	
2	1							
5	6							
<table border="1"><tr><td>2</td><td>1</td></tr><tr><td>6</td><td>6</td></tr></table>	2	1	6	6	$G_{U1} = \min[D_{p2} - Y_2 - R_{c2}, D_{p6} - Y_6 - R_{c6}] - G_{q2}$	$I_{1,1}$	0.0	
2	1							
6	6							
Perm- Lead	<table border="1"><tr><td>2</td><td>6</td></tr><tr><td>5</td><td>6</td></tr></table>	2	6	5	6	$G_{U1} = D_{p2} - Y_2 - R_{c2} - \max[D_{p5}, G_{q2}]$	$I_{1,1}$	e_1
2	6							
5	6							
Perm- Lag	<table border="1"><tr><td>2</td><td>6</td></tr><tr><td>6</td><td>5</td></tr></table>	2	6	6	5	$G_{U1} = \min[D_{p2} - Y_2 - R_{c2}, D_{p6} - Y_6 - R_{c6}] - G_{q2}$	$I_{1,1}$	e_1
2	6							
6	5							
Perm- Perm	<table border="1"><tr><td>2</td><td>6</td></tr></table>	2	6	$G_{U1} = D_{p2} - Y_6 - R_{c6} - G_{q2}$	$I_{1,1}$	e_1		
2	6							
Lag- Lag	<table border="1"><tr><td>2</td><td>1</td></tr><tr><td>6</td><td>5</td></tr></table>	2	1	6	5	$G_{U1} = \min[D_{p2} - Y_2 - R_{c2}, D_{p6} - Y_6 - R_{c6}] - G_{q2}$	$I_{1,1}$	e_1^*
	2	1						
6	5							
	<table border="1"><tr><td>2</td><td>1</td></tr><tr><td>6</td><td>5</td></tr></table>	2	1	6	5	$G_{U1} = \min[D_{p2} - Y_2 - R_{c2}, D_{p6} - Y_6 - R_{c6}] - G_{q2}$	$I_{1,1}$	e_1^*
2	1							
6	5							

Notes: ^a G_{q2} is computed for each opposing lane (excluding any opposing shared left-turn lane), and the value used corresponds to the lane requiring the longest time to clear. In general, if the opposing lanes serve through movements exclusively, then $G_{q2} = g_q + I_1$. If an opposing lane is shared, then $G_{q2} = g_p - g_e + I_1$, where g_p is the effective green time for permitted operation (s), g_e is the green extension time (s), and I_1 is the start-up lost time (s).
^b If $D_{p5} > (D_{p1} - Y_1 - R_{c1})$, then $I_1^* = D_{p5} - (D_{p1} - Y_1 - R_{c1}) + I_1 - e_1$; otherwise, $I_1^* = 0.0$. Regardless, the result should not be less than 0.0 or more than I_1 .
^c $e_1^* = D_{p2} - (D_{p6} - Y_6 - R_{c6})$, provided the result is not less than 0.0 or more than e_1 .
 Perm = permitted.

For the first four variables in the preceding list, the subscript "1" is added to the variable when it is used in an Exhibit 31-12 equation. This subscript denotes Movement 1. For the next four variables in the list, a numeric subscript is added to the variable when it is used in an equation from the exhibit. This subscript denotes the phase number associated with the variable. Exhibit 31-12 applies only to left-turn Movement 1. The subscripts need to be changed to apply the equations to other left-turn movements.

The equations shown in Exhibit 31-12 indicate that the effective green time for the permitted operation of Phase 1 depends on the duration of Phase 2 and

sometimes the duration of Phase 5. In all instances, Movement 1 has permitted operation during all, or a portion of, Phase 6.

For a given left-turn lane group, one of the equations in the second column (Displayed Unblocked Permitted Green Time) of Exhibit 31-12 will apply. It is used to compute the displayed green interval corresponding to g_u (i.e., G_U). The computed G_U is required to have a nonnegative value. If the calculation yields a negative value, then G_U is set to 0.0.

The same equation can be used to compute the displayed green interval corresponding to g_p (i.e., G_p) by substituting G_p for G_U and 0.0 for G_q . Again, the computed G_p is required to have a nonnegative value. If the calculation yields a negative value, then G_p is set to 0.0.

Equation 31-94 is used to compute the effective green time for permitted left-turn operation.

$$g_p = G_p - l_{1,p} + e_p \geq 0.0$$

Equation 31-94

where

g_p = effective green time for permitted left-turn operation (s),

G_p = displayed green interval corresponding to g_p (s),

$l_{1,p}$ = permitted start-up lost time (s), and

e_p = permitted extension of effective green (s).

The values of $l_{1,p}$ and e_p used in Equation 31-94 are obtained from the two right-hand columns (Permitted Start-Up Lost Time and Permitted Extension Time, respectively) of Exhibit 31-12.

The start-up lost time for g_u is considered to occur coincident with the start-up lost time associated with g_p . Hence, if the opposing-queue service time consumes an initial portion of g_p , then there is no start-up lost time associated with g_u . The rationale for this approach is that left-turn drivers waiting for the opposing queue to clear will be anticipating queue clearance and may be moving forward slowly (perhaps already beyond the stop line) so that there is negligible start-up lost time at this point. This approach also accommodates the consideration of multiple effective green-time terms when there is a shared lane (e.g., g_j), and it avoids inclusion of multiple start-up lost times during g_p . In accordance with this rationale, Equation 31-95 is used to compute the permitted left-turn green time that is not blocked by an opposing queue g_u , where all other variables are as previously defined.

$$g_u = G_u + e_p \leq g_p$$

Equation 31-95

If protected-permitted operation exists and Dallas phasing is used, then the displayed green interval corresponding to g_u (i.e., G_U) is equal to the opposing through phase duration minus the queue service time and change period of the opposing through phase (i.e., $G_{U1} = D_{p2} - Y_2 - R_{c2} - G_{q2}$). The permitted start-up lost time $l_{1,p}$ and permitted extension of effective green e_p are equal to l_1 and e , respectively. Otherwise, all the calculations described previously apply.

Step 2. Determine Time Before First Left-Turn Vehicle Arrives

This step applies when the left-turn movement is served by using the permitted mode on a shared-lane approach. The variable of interest represents the time that elapses from the start of the permitted green to the arrival of the first left-turning vehicle at the stop line. During this time, through vehicles in the shared lane are served at the saturation flow rate of an exclusive through lane.

Considerations of vehicle distribution impose an upper limit on the time before the first left-turn vehicle arrives when it is used to define a period of saturation flow. This limit is computed with Equation 31-96.

Equation 31-96

$$g_{f,max} = \frac{(1 - P_L)}{0.5 P_L} (1 - [1 - P_L]^{0.5 g_p}) - l_{1,p} \geq 0.0$$

where $g_{f,max}$ is the maximum time before the first left-turning vehicle arrives and within which there are sufficient through vehicles to depart at saturation (s), P_L is the proportion of left-turning vehicles in the shared lane (decimal), and all other variables are as previously defined.

The value of 0.5 in two locations in Equation 31-96 represents the approximate saturation flow rate (in vehicles per second) of through vehicles in an exclusive lane. This approximation simplifies the calculation and provides sufficient accuracy in the estimate of $g_{f,max}$.

The time before the first left-turning vehicle arrives and blocks the shared lane is computed with Equation 31-97 or Equation 31-98, along with Equation 31-99.

If the approach has one lane, then

Equation 31-97

$$g_f = \max (G_p e^{-0.860 LTC^{0.629}} - l_{1,p}, 0.0) \leq g_{f,max}$$

otherwise

Equation 31-98

$$g_f = \max (G_p e^{-0.882 LTC^{0.717}} - l_{1,p}, 0.0) \leq g_{f,max}$$

with

Equation 31-99

$$LTC = \frac{v_{lt} C}{3,600}$$

where

g_f = time before the first left-turning vehicle arrives and blocks the shared lane (s),

LTC = left-turn flow rate per cycle (veh/cycle), and

v_{lt} = left-turn demand flow rate (veh/h).

The approach is considered to have one lane for this step if (a) there is one lane serving all vehicles on the approach and (b) the left-turn movement on this approach shares the one lane.

Step 3. Determine Permitted Left-Turn Saturation Flow Rate

This step applies when left-turning vehicles are served by using the permitted mode or the protected-permitted mode from an exclusive lane. The saturation flow rate for permitted left-turn operation is calculated with Equation 31-100.

$$s_p = \frac{v_o e^{-v_o t_{cg}/3,600}}{1 - e^{-v_o t_{fh}/3,600}}$$

Equation 31-100

where

s_p = saturation flow rate of a permitted left-turn movement (veh/h/ln),

v_o = opposing demand flow rate (veh/h),

t_{cg} = critical headway = 4.5 (s), and

t_{fh} = follow-up headway = 2.5 (s).

The opposing demand flow rate v_o is determined to be one of two cases. In Case 1, v_o equals the sum of the opposing through and right-turn volumes. In Case 2, v_o equals the opposing through volume. Case 2 applies when there is a through movement on the opposing approach and one of the following conditions applies: (a) there is an exclusive right-turn lane on the opposing approach and the analyst optionally indicates that this lane does not influence the left-turn drivers' gap acceptance, or (b) there is no right-turn movement on the opposing approach. Case 1 applies whenever Case 2 does not apply.

When an exclusive right-turn lane exists on the opposing approach, the default condition is to assume this lane influences the subject left-turn drivers' gap acceptance. The determination that the exclusive right-turn lane does not influence gap acceptance should be based on knowledge of local driver behavior, traffic conditions, and intersection geometry.

In those instances in which the opposing volume equals 0.0 veh/h during the analysis period, the opposing volume is set to a value of 0.1 veh/h.

The opposing demand flow rate is not adjusted for unequal lane use in this equation. Increasing this flow rate to account for unequal lane use would misrepresent the frequency and size of headways in the opposing traffic stream. Thus, this adjustment would result in the left-turn saturation flow rate being underestimated.

Step 4. Determine Through-Car Equivalent

This step applies when left-turning vehicles are served by using the permitted mode or the protected-permitted mode. Two variables are computed to quantify the relationship between left-turn saturation flow rate and the base saturation flow rate. The first variable represents the more common case in which left-turning vehicles filter through an oncoming traffic stream. It is computed from Equation 31-101.

$$E_{L1} = \frac{s_o}{s_p}$$

Equation 31-101

where

E_{L1} = equivalent number of through cars for a permitted left-turning vehicle,

s_o = base saturation flow rate (pc/h/ln), and

s_p = saturation flow rate of a permitted left-turn movement (veh/h/ln).

The second variable to be computed represents the case in which the opposing approach has one lane. It describes the saturation flow rate during the time interval coincident with the queue service time of the opposing queue. For this case, the saturation flow rate during the period after the arrival of the first blocking left-turning vehicle and before the end of the opposing-queue service time is influenced by the proportion of left-turning vehicles in the opposing traffic stream. These vehicles create artificial gaps in the opposing traffic stream through which the blocking left-turning vehicles on the subject approach can turn. This effect is considered through calculation of the following through-car equivalency factor by using Equation 31-102 with Equation 31-103.

Equation 31-102

$$E_{L2} = \frac{1 - (1 - P_{lto})^{n_q}}{P_{lto}} \geq E_L$$

with

Equation 31-103

$$n_q = 0.278(g_p - g_u - g_f) \geq 0.0$$

where

E_{L2} = equivalent number of through cars for a permitted left-turning vehicle when opposed by a queue on a single-lane approach,

P_{lto} = proportion of left-turning vehicles in the opposing traffic stream (decimal),

n_q = maximum number of opposing vehicles that could arrive after g_f and before g_u (veh), and

all other variables are as previously defined.

The value of 0.278 in Equation 31-103 represents the approximate saturation flow rate (in vehicles per second) of vehicles in the opposing shared lane. This approximation simplifies the calculation and provides sufficient accuracy in the estimation of n_q .

There is one lane on the opposing approach when this approach has one lane serving through vehicles, a left-turn movement that shares the through lane, and one of the following conditions applies: (a) there is an exclusive right-turn lane on the opposing approach and the analyst optionally indicates that this lane does not influence the left-turn drivers' gap acceptance, (b) there is a right-turn movement on the opposing approach and it shares the through lane, or (c) there is no right-turn movement on the opposing approach.

When an exclusive right-turn lane exists on the opposing approach, the default condition is to assume this lane influences the subject left-turn drivers' gap acceptance. The determination that the exclusive right-turn lane does not influence gap acceptance should be based on knowledge of local driver behavior, traffic conditions, and intersection geometry.

Step 5. Determine Proportion of Turns in a Shared Lane

This step applies when turning vehicles share a lane with through vehicles and the approach has two or more lanes. The proportion of turning vehicles in the shared lane is used in the next step to determine the saturation flow rate for the shared lane.

The proportion of left-turning vehicles in the shared lane P_L is computed if the shared lane includes left-turning vehicles. The proportion of right-turning vehicles in the shared lane P_R is computed if the shared lane includes right-turning vehicles. Guidance for computing these two variables is provided in Section 2.

If the approach has one traffic lane, then P_L equals the proportion of left-turning vehicles on the subject approach P_{lv} and P_R equals the proportion of right-turning vehicles on the subject approach P_{rt} .

Step 6. Determine Lane Group Saturation Flow Rate

The saturation flow rate for the lane group is computed during this step. When the lane group consists of an exclusive lane operating in the protected mode, then it has one saturation flow rate. This rate equals the adjusted saturation flow rate computed by the procedure described in the motorized vehicle methodology in Section 3 of Chapter 19.

The focus of discussion in this step is the calculation of saturation flow rate for lane groups that are *not* in an exclusive lane or operating in the protected mode. Thus, the discussion in this step focuses on shared-lane lane groups and lane groups for which the permitted or protected-permitted mode is used. As the discussion indicates, these lane groups often have two or more saturation flow rates, depending on the phase sequence and operational mode of the turn movements.

Permitted Right-Turn Operation in Exclusive Lane

The saturation flow rate for a permitted right-turn operation in an exclusive lane is computed with Equation 31-104.

$$s_r = s_o f_w f_{HVg} f_p f_{bb} f_a f_{LU} f_{RT} f_{Rpb} f_{wz} f_{ms} f_{sp}$$

where s_r is the saturation flow rate in an exclusive right-turn lane group with permitted operation (veh/h/ln), and the other variables are defined following Equation 19-8 in Chapter 19.

Permitted Right-Turn Operation in Shared Lane

The saturation flow rate for permitted right-turn operation in a shared lane is computed with Equation 31-105.

$$s_{sr} = \frac{s_{th}}{1 + P_R \left(\frac{E_R}{f_{Rpb}} - 1 \right)}$$

Equation 31-104

Equation 31-105

where

s_{sr} = saturation flow rate in shared right-turn and through lane group with permitted operation (veh/h/ln),

s_{th} = saturation flow rate of an exclusive through lane (= base saturation flow rate adjusted for lane width, heavy vehicles, grade, parking, buses, area type, work zone presence, downstream lane blockage, and spillback) (veh/h/ln),

P_R = proportion of right-turning vehicles in the shared lane (decimal),

E_R = equivalent number of through cars for a protected right-turning vehicle = 1.18, and

f_{Rpb} = pedestrian-bicycle adjustment factor for right-turn groups.

The value of f_{Rpb} is obtained by the procedure described in Section 2.

Protected-Permitted Right-Turn Operation in Exclusive Lane

Two saturation flow rates are associated with protected-permitted operation. The saturation flow rate during the protected period s_{rt} is computed with Equation 31-106.

Equation 31-106

$$s_{rt} = s_o f_w f_{HVg} f_p f_{bb} f_a f_{LU} f_{RT} f_{wz} f_{ms} f_{sp}$$

where s_{rt} is the saturation flow rate of an exclusive right-turn lane with protected operation (veh/h/ln), and the other variables are defined following Equation 19-8 in Chapter 19.

The saturation flow rate during the permitted period is computed with Equation 31-104.

Permitted Left-Turn Operation in Shared Lane

There are three possible saturation flow periods during the effective green time associated with permitted left-turn operation in a shared lane. The first period occurs before the arrival of the first left-turning vehicle in the shared lane. This left-turning vehicle will block the shared lane until the opposing queue clears and a gap is available in the opposing traffic stream. The duration of this flow period is g_f . The saturation flow during this period is equal to s_{th} .

The second period of flow begins after g_f and ends with clearance of the opposing queue. It is computed with Equation 31-107.

Equation 31-107

$$g_{diff} = g_p - g_u - g_f \geq 0.0$$

where g_{diff} is the supplemental service time (s), and all other variables are as previously defined. This period may or may not exist, depending on the values of g_u and g_f .

If there are two or more opposing traffic lanes, then the saturation flow during the second period $s_{s/2}$ equals 0.0 veh/h/ln. However, if the opposing approach has only one traffic lane, then the flow during this period occurs at a reduced rate that reflects the blocking effect of left-turning vehicles as they await an opposing left-turning vehicle. Left-turning vehicles during this period are

assigned a through-car equivalent E_{L2} . The saturation flow rate for the shared lane is computed with Equation 31-108.

$$s_{sl2} = \frac{s_{th}}{1 + P_L \left(\frac{E_{L2}}{f_{Lpb}} - 1 \right)}$$

Equation 31-108

where s_{sl2} is the saturation flow rate in the shared left-turn and through lane group during Period 2 (veh/h/ln), P_L is the proportion of left-turning vehicles in the shared lane (decimal), and all other variables are as previously defined.

There is one lane on the opposing approach when this approach has one lane serving through vehicles, a left-turn movement that shares the through lane, and one of the following conditions applies: (a) there is an exclusive right-turn lane on the opposing approach and the analyst optionally indicates that this lane does not influence the left-turn drivers' gap acceptance, (b) there is a right-turn movement on the opposing approach and it shares the through lane, or (c) there is no right-turn movement on the opposing approach.

When an exclusive right-turn lane exists on the opposing approach, the default condition is to assume this lane influences the subject left-turn drivers' gap acceptance. The determination that the exclusive right-turn lane does not influence gap acceptance should be based on knowledge of local driver behavior, traffic conditions, and intersection geometry.

The third period of flow begins after clearance of the opposing queue or arrival of the first blocking left-turn vehicle, whichever occurs last. Its duration equals the smaller of $g_p - g_f$ or g_u . The saturation flow rate for this period is computed with Equation 31-109.

$$s_{sl3} = \frac{s_{th}}{1 + P_L \left(\frac{E_{L1}}{f_{Lpb}} - 1 \right)}$$

Equation 31-109

where s_{sl3} is the saturation flow rate in the shared left-turn and through lane group during Period 3 (veh/h/ln).

For multiple-lane approaches, the impact of the shared lane is extended to include the adjacent through traffic lanes. Specifically, queued drivers are observed to maneuver from lane to lane on the approach to avoid delay associated with the left-turning vehicles in the shared lane. The effect of this impact is accounted for by multiplying the saturation flow rate of the adjacent lanes by a factor of 0.91.

Permitted Left-Turn Operation in Exclusive Lane

There are two possible saturation flow periods during the effective green time associated with permitted left-turn operation in an exclusive lane. The two flow periods are discussed in reverse order, with the second period of flow discussed first.

The second period of flow begins after clearance of the opposing queue. Its duration is g_u . The saturation flow rate for this period is computed with Equation 31-110.

Equation 31-110

$$s_l = s_p f_w f_{HVg} f_p f_{bb} f_a f_{LU} f_{Lpb} f_{wz} f_{ms} f_{sp}$$

where s_l is the saturation flow rate in an exclusive left-turn lane group with permitted operation (veh/h/ln), and all other variables are defined following Equation 19-8 in Chapter 19.

The first period of flow begins with the start of the effective green period and ends with the clearance of the opposing queue. It is computed by using Equation 31-107 with the variable g_f equal to 0.0.

If there are two or more opposing traffic lanes, then the saturation flow during the first period s_{l1} equals 0.0 veh/h/ln. However, if the opposing approach has only one traffic lane, then the saturation flow rate is computed with Equation 31-111.

Equation 31-111

$$s_{l1} = \frac{s_l}{\left(\frac{E_{L2}}{f_{Lpb}}\right)}$$

where s_{l1} is the saturation flow rate in the exclusive left-turn lane group during Period 1 (veh/h/ln). The discussion following Equation 31-108 provides guidance for determining whether the opposing approach has only one traffic lane.

Protected-Permitted Left-Turn Operation in Exclusive Lane

Two saturation flow rates are associated with protected-permitted operation. The saturation flow rate during the protected period s_{lt} is computed with Equation 31-112.

Equation 31-112

$$s_{lt} = s_o f_w f_{HVg} f_p f_{bb} f_a f_{LU} f_{LT} f_{wz} f_{ms} f_{sp}$$

where s_{lt} is the saturation flow rate of an exclusive left-turn lane with protected operation (veh/h/ln), and all other variables are defined following Equation 19-8 in Chapter 19.

The saturation flow rate during the permitted period is computed with Equation 31-110. The duration of the permitted period is equal to g_u .

Protected-Permitted Left-Turn Operation in Shared Lane

The use of a protected-permitted operation in a shared lane has some special requirements to ensure safe and efficient operation. This operational mode requires display of the green ball when the left-turn green arrow is displayed (i.e., the green arrow is not displayed without also displaying the circular green). The following conditions are applied for actuated, protected-permitted operation in a shared lane:

- The left-turn phase is set to minimum recall.
- The maximum green setting for the left-turn phase must be less than or equal to the minimum green for the adjacent through phase.
- If both opposing approaches have protected-permitted operation in a shared lane, then the phase sequence must be lead-lag.
- No vehicle detection is assigned to the left-turn phase.
- Vehicle detection in the shared lane is assigned to the adjacent through movement phase.

There are four possible saturation flow periods during the effective green time associated with protected-permitted left-turn operation in a shared lane. The first three periods are the same as those for permitted left-turn operation in a shared lane (as described above).

The fourth period of flow coincides with the left-turn phase (i.e., the protected period). Its duration is equal to the effective green time for the left-turn phase g_l . The flow rate during this period is computed with Equation 31-113.

$$s_{sl4} = \frac{s_{th}}{1 + P_L(E_L - 1)}$$

Equation 31-113

where s_{sl4} is the saturation flow rate in the shared left-turn and through lane group during Period 4 (veh/h/ln).

For multiple-lane approaches, the impact of the shared lane is extended to include the adjacent through lanes. This impact is accounted for by multiplying the saturation flow rate of the adjacent lanes by a factor of 0.91.

Protected Left- and Right-Turn Operation in a Shared Lane

The saturation flow rate in a shared left- and right-turn lane group with protected operation is computed with Equation 31-114.

$$s_{lr} = \frac{s_{th}}{1 + P_L(E_L - 1) + P_R(E_R - 1)}$$

Equation 31-114

where s_{lr} is the saturation flow rate in the shared left- and right-turn lane group (veh/h/ln).

Step 7. Define Queue Accumulation Polygon

During this step, the green times and saturation flow rates are used to construct the QAP associated with each lane group. The polygon is then used to estimate uniform delay and queue service time. The lane group with the longest queue service time dictates the queue service time for the phase.

The QAP in Exhibit 31-11 applies to either a through lane group or a left- or right-turn lane group with exclusive lanes operating with the protected mode. This polygon also applies to split phasing and to shared lane groups serving through and right-turning vehicles operating with the permitted mode. For split phasing, each approach is evaluated separately to determine its queue service time and uniform delay. If the approach has left- or right-turn lanes, then a separate polygon is constructed for each turn lane group.

More complicated combinations of lane assignment, phase sequence, and left-turn operational mode dictate more complicated polygons. A polygon (or its tabular equivalent) must be derived for each combination. The most common combinations are illustrated in Exhibit 31-13 through Exhibit 31-16.

Exhibit 31-13
QAP for Permitted Left-Turn
Operation in an Exclusive
Lane

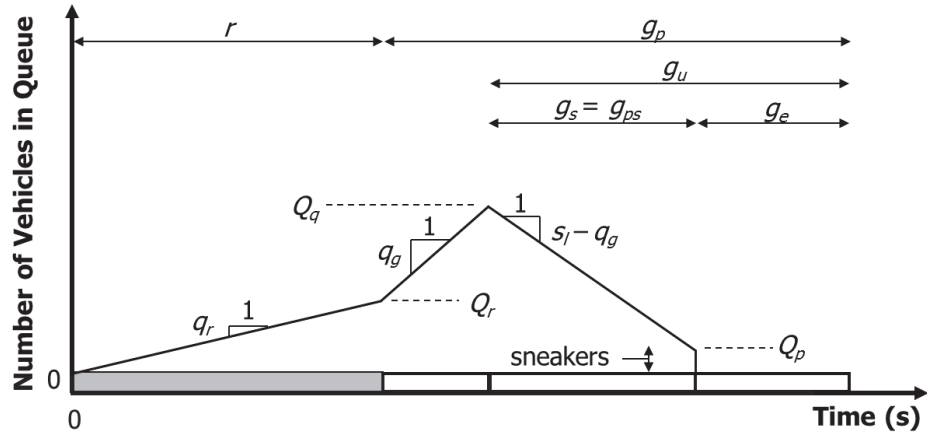

Exhibit 31-14
QAP for Permitted Left-Turn
Operation in a Shared Lane

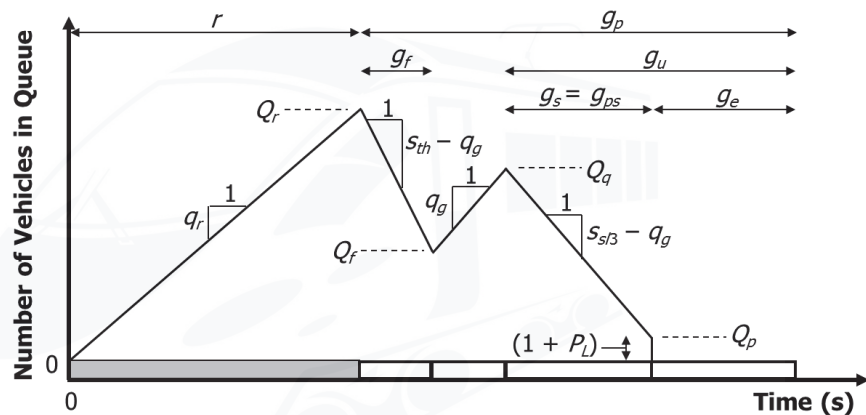
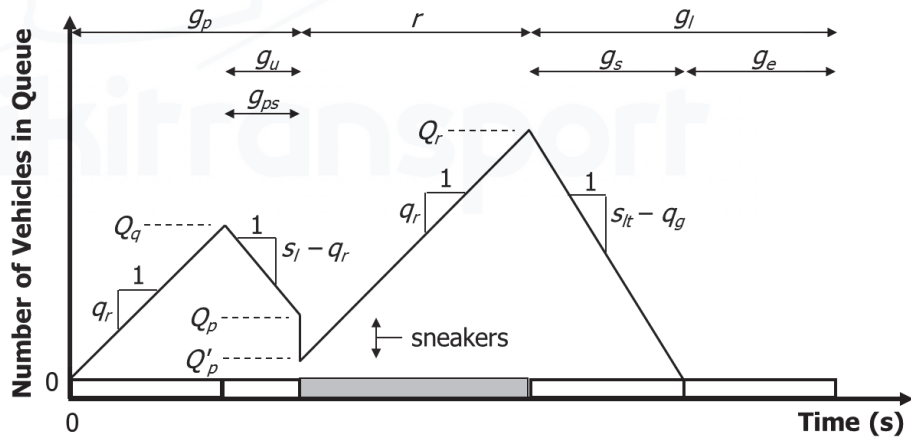

Exhibit 31-15
QAP for Leading, Protected-
Permitted Left-Turn Operation
in an Exclusive Lane



The concept is extended to shared left-turn and through lane groups with protected-permitted operation in Exhibit 31-17 and Exhibit 31-18. Other polygon shapes exist, depending on traffic flow rates, phase sequence, lane use, and left-turn operational mode. The concept of polygon construction must be extended to these other combinations to accurately estimate queue service time and uniform delay.

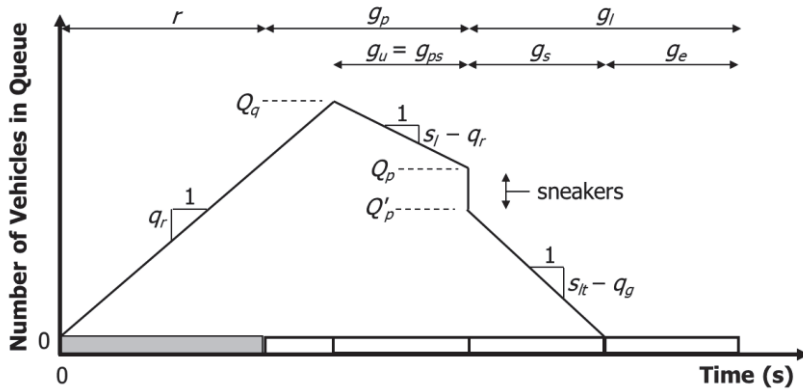

Exhibit 31-16
QAP for Lagging, Protected-Permitted Left-Turn Operation in an Exclusive Lane

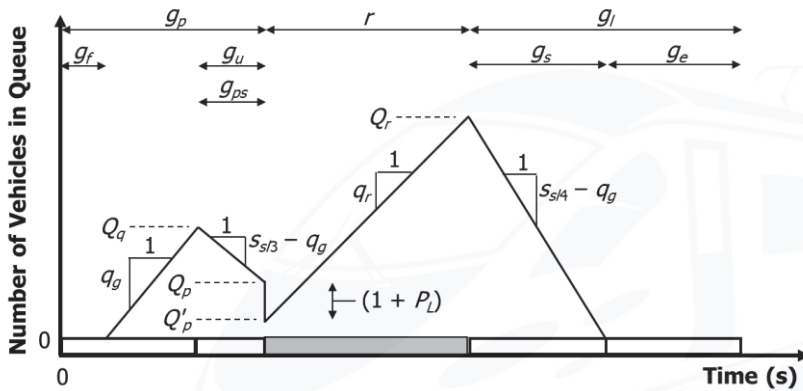

Exhibit 31-17
QAP for Leading, Protected-Permitted Left-Turn Operation in a Shared Lane

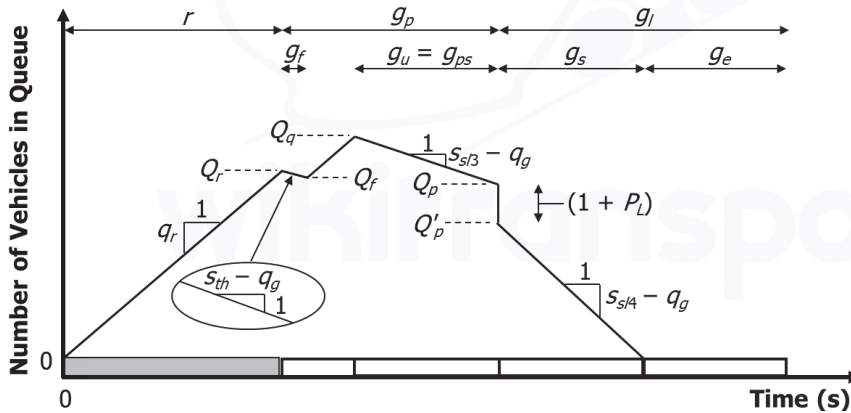

Exhibit 31-18
QAP for Lagging, Protected-Permitted Left-Turn Operation in a Shared Lane

Most of the variables shown in the following exhibits are defined in a previous subsection. Other variables are defined as follows:

- g_l = effective green time for left-turn phase (s);
- g_{ps} = queue service time during permitted left-turn operation (s);
- Q_q = queue size at the start of g_u (veh);
- Q_p = queue size at the end of permitted service time (veh);
- Q'_p = queue size at the end of permitted service time, adjusted for sneakers (veh); and

Q_f = queue size at the end of g_f (veh).

The polygon in Exhibit 31-13 applies to the left-turn lane group with an exclusive lane that operates in the permitted mode during the adjacent through phase. If the phase extends to max-out, then some left-turning vehicles will be served as sneakers. The expected number of sneakers for this mode is reduced if downstream lane blockage or spillback is present [i.e., sneakers = $n_s f_{ms} f_{sp}$ where n_s is the number of sneakers per cycle = 2.0 (veh), f_{ms} is the adjustment factor for downstream lane blockage, and f_{sp} is the adjustment factor for sustained spillback].

The polygon in Exhibit 31-14 applies to the left-turn and through lane group on a shared lane approach with permitted operation. If the phase extends to max-out, then some left-turning vehicles will be served as sneakers. The expected number of sneakers (shown as $1 + P_L$) is computed as $(1 + P_L) f_{ms} f_{sp}$ where P_L is the proportion of left-turning vehicles in the shared lane.

The polygon in Exhibit 31-15 applies to left-turn movements that have protected-permitted operation with a leading left-turn phase and an exclusive lane. The polygon in Exhibit 31-16 applies to left-turn movements that have protected-permitted operation with a lagging left-turn phase and an exclusive lane. If a queue exists at the end of the permitted period for either polygon, then the queue is reduced by the number of sneakers (where sneakers = $n_s f_{ms} f_{sp}$).

The polygon in Exhibit 31-17 applies to left-turn movements that have protected-permitted operation with a leading left-turn phase and a shared left-turn and through lane group. The polygon in Exhibit 31-18 applies to the same movements and operation but with a lagging left-turn phase. If a queue exists at the end of the permitted period for either polygon, then the queue is reduced by the expected number of sneakers [which is computed as $(1 + P_L) f_{ms} f_{sp}$].

As noted above, all polygons are based on the requirement that lane volume cannot exceed lane capacity for the purpose of estimating the queue service time. This requirement is met in the polygons shown because the queue size equals 0.0 vehicles at some point during the cycle.

Exhibit 31-14 through Exhibit 31-18 are shown to indicate that queue size equals 0.0 vehicles at the start of the cycle (i.e., time = 0.0 s). In fact, the queue may not equal 0.0 vehicles at the start of the cycle for some signal timing and traffic conditions. Rather, there may be a nonzero queue at the start of the cycle, and a queue of 0.0 vehicles may not be reached until a different time in the cycle. Thus, in modeling any of the polygons in Exhibit 31-14 through Exhibit 31-18, an iterative process is required. For the first iteration, the queue is assumed to equal 0.0 vehicles at the start of the cycle. The polygon is then constructed, and the queue status is checked at the end of the cycle. If the queue at the end of the cycle is not 0.0 vehicles, then this value is used as a starting point in a second polygon construction. The second polygon will result in a queue at the end of the cycle that equals the queue used at the start of the cycle. Moreover, a queue value of 0.0 vehicles will occur at some point in the cycle.

A. Compute Uniform Delay and Queue Service Time

The procedure for calculating uniform delay and queue service time is described in this step. Exhibit 31-19 is used for this purpose.

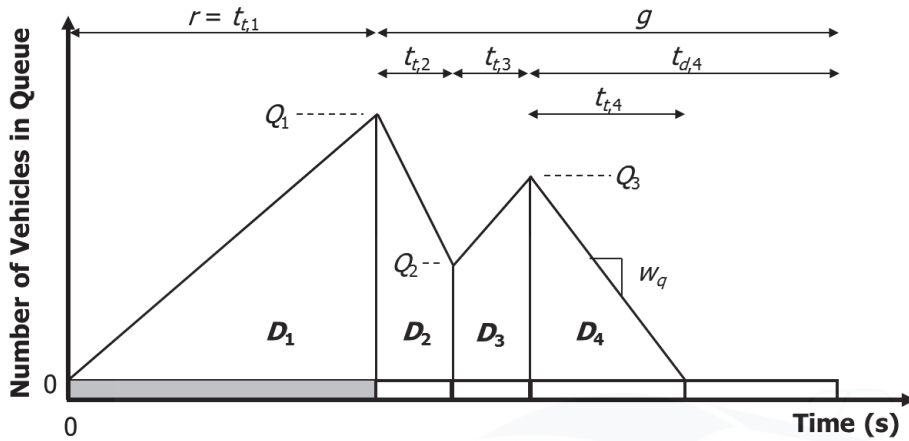

Exhibit 31-19
Polygon for Uniform Delay Calculation

The area bounded by the polygon represents the total delay incurred during the average cycle. The total delay is then divided by the number of arrivals per cycle to estimate the average uniform delay. These calculations are summarized in Equation 31-115 with Equation 31-116.

$$d_1 = \frac{0.5 \sum_{i=1} (Q_{i-1} + Q_i) t_{t,i}}{q C}$$

Equation 31-115

with

$$t_{t,i} = \min(t_{d,i}, Q_{i-1}/w_q)$$

Equation 31-116

where d_1 is the uniform delay (s/veh), $t_{t,i}$ is the duration of trapezoid or triangle in interval i (s), w_q is the queue change rate (i.e., slope of the upper boundary of the trapezoid or triangle) (veh/s), and all other variables are as previously defined.

The summation term in Equation 31-115 includes all intervals for which there is a nonzero queue. In general, $t_{t,i}$ will equal the duration of the corresponding interval. However, during some intervals, the queue will decrease to 0.0 vehicles and $t_{t,i}$ will be only as long as the time required for the queue to dissipate ($= Q_{i-1}/w_q$). This condition is shown to occur during Time Interval 4 in Exhibit 31-19.

The time required for the queue to dissipate represents the queue service time. The queue can dissipate during one or more intervals for turn movements that operate in the protected-permitted mode and for shared-lane lane groups.

For lane groups with exclusive lanes and protected operation, there is one queue service time. It is followed by the green extension time.

For permitted left-turn operation in an exclusive lane, there is one queue service time. It is followed by the green extension time.

For permitted left-turn operation in a shared lane, there can be two queue service times. The green extension time follows the last service time to occur.

For protected-permitted left-turn operation in an exclusive lane, there can be two queue service times. The service time that ends during the protected period is followed by the green extension time.

For protected-permitted left-turn operation in a shared lane, there can be three queue service times. The green extension time can follow the service time that ends during the protected period, but it is more likely to follow the last service time to occur during the permitted period.

For phases serving through or right-turning vehicles in two or more lane groups, the queue service time is measured from the start of the phase to the time when the queue in each lane group has been serviced (i.e., the longest queue service time controls). This consideration is extended to lane groups with shared through and left-turning vehicles.

B. Calculate Lane Group Capacity

This step describes the procedure used to calculate lane group capacity. It is based on the QAP and considers all opportunities for service during the cycle. The equations vary, depending on the left-turn operational mode, phase sequence, and lane assignments for the subject lane group.

Protected Left-Turn Operation in Exclusive Lane

The capacity for a protected left-turn operation in an exclusive-lane lane group is computed with Equation 31-117.

Equation 31-117

$$c_{l,e,p} = \frac{g_l s_{lt}}{C} N_l$$

where $c_{l,e,p}$ is the capacity of an exclusive-lane lane group with protected left-turn operation (veh/h), g_l is the effective green time for the left-turn phase (s), N_l is the number of lanes in the exclusive left-turn lane group (ln), and all other variables are as previously defined.

The available capacity for the lane group is computed with Equation 31-118.

Equation 31-118

$$c_{a,l,e,p} = \frac{G_{max} s_{lt}}{C} N_l$$

where $c_{a,l,e,p}$ is the available capacity of an exclusive-lane lane group with protected left-turn operation (veh/h), G_{max} is the maximum green setting (s), and all other variables are as previously defined.

Equation 31-117 and Equation 31-118 can also be used to calculate the capacity of lane groups composed of through lanes and lane groups composed of right-turn lanes with proper substitution of saturation flow rate, number of lanes, and maximum green variables.

Permitted Left-Turn Operation in Exclusive Lane

The capacity for a permitted left-turn operation in an exclusive-lane lane group is computed with Equation 31-119.

Equation 31-119

$$c_{l,e} = \frac{g_u s_l + 3,600 n_s f_{ms} f_{sp}}{C} N_l$$

where $c_{l,e}$ is the capacity of an exclusive-lane lane group with permitted left-turn operation (veh/h), n_s is the number of sneakers per cycle = 2.0 (veh), and all other variables are as previously defined.

The available capacity for the lane group is computed with Equation 31-120.

$$c_{a,l,e} = c_{l,e} + \frac{(G_{max} - g) s_l}{C} N_l$$

Equation 31-120

where $c_{a,l,e}$ is the available capacity of an exclusive-lane lane group with permitted left-turn operation (veh/h), and all other variables are as previously defined.

The saturation flow rate s_l is specifically included in the term with the maximum green setting G_{max} in Equation 31-120 because this rate represents the saturation flow rate present at the end of the green interval. That is, it is the saturation flow rate that would occur when the green is extended to its maximum green limit as a result of cycle-by-cycle fluctuations in the demand flow rate.

Permitted Left-Turn Operation in Shared Lane

The capacity for a permitted left-turn operation in a shared-lane lane group is computed with Equation 31-121.

$$c_{sl} = \frac{g_p s_{sl} + 3,600(1 + P_L) f_{ms} f_{sp}}{C}$$

Equation 31-121

where c_{sl} is the capacity of a shared-lane lane group with permitted left-turn operation (veh/h), s_{sl} is the saturation flow rate in a shared left-turn and through lane group with permitted operation (veh/h/ln), and all other variables are as previously defined.

The saturation flow rate in Equation 31-121 is computed with Equation 31-122 (all variables are as previously defined).

$$s_{sl} = \frac{s_{th}}{g_p} \left(g_f + \frac{g_{diff}}{1 + P_L \left[\frac{E_{L2}}{f_{Lpb}} - 1 \right]} + \frac{\min(g_p - g_f, g_u)}{1 + P_L \left[\frac{E_{L1}}{f_{Lpb}} - 1 \right]} \right)$$

Equation 31-122

The available capacity for the lane group is computed with Equation 31-123.

$$c_{a,sl} = c_{sl} + \frac{(G_{max} - g_p) s_{sl3}}{C}$$

Equation 31-123

where $c_{a,sl}$ is the available capacity of a shared-lane lane group with permitted left-turn operation (veh/h).

The saturation flow rate s_{sl3} is specifically included in the term with the maximum green setting G_{max} in Equation 31-123 because this rate represents the saturation flow rate present at the end of the green interval.

Protected-Permitted Left-Turn Operation in Exclusive Lane

The capacity for a protected-permitted left-turn operation in an exclusive-lane lane group is computed with Equation 31-124.

$$c_{l,e,pp} = \left(\frac{g_l s_{lt}}{C} + \frac{g_u s_l + 3,600 n_s f_{ms} f_{sp}}{C} \right) N_l$$

Equation 31-124

where $c_{l,e,pp}$ is the capacity of an exclusive-lane lane group with protected-permitted left-turn operation (veh/h).

The available capacity for the lane group is computed with Equation 31-125.

Equation 31-125

$$c_{a,l,e,pp} = \left(\frac{G_{max} s_{lt}}{C} + \frac{g_u s_l + 3,600 n_s f_{ms} f_{sp}}{C} \right) N_l$$

where $c_{a,l,e,pp}$ is the available capacity of an exclusive-lane lane group with protected-permitted left-turn operation (veh/h) and all other variables are as previously defined.

Protected-Permitted Left-Turn Operation in Shared Lane

The capacity for a protected-permitted left-turn operation in a shared-lane lane group is computed with Equation 31-126.

Equation 31-126

$$c_{sl,pp} = \frac{g_l s_{sl4}}{C} + \frac{g_p s_{sl} + 3,600(1 + P_L) f_{ms} f_{sp}}{C}$$

where $c_{sl,pp}$ is the capacity of a shared-lane lane group with protected-permitted left-turn operation (veh/h).

If the lane group is associated with a leading left-turn phase, then the available capacity for the lane group is computed with Equation 31-127.

Equation 31-127

$$c_{a,sl,pp} = c_{sl,pp} + \frac{(G_{max} - g_p) s_{sl3}}{C}$$

where $c_{a,sl,pp}$ is the available capacity of a shared-lane lane group with protected-permitted left-turn operation (veh/h).

When the lane group is associated with a lagging left-turn phase, then the variable s_{sl3} in Equation 31-127 is replaced by s_{sl4} .

Protected-Permitted Right-Turn Operation in Exclusive Lane

The capacity for a protected-permitted right-turn operation in an exclusive-lane lane group is computed with Equation 31-128.

Equation 31-128

$$c_{r,e,pp} = \left(\frac{g_l s_{rt}}{C} + \frac{g_r s_r}{C} \right) N_r$$

where $c_{r,e,pp}$ is the capacity of an exclusive-lane lane group with protected-permitted right-turn operation (veh/h), g_l is the effective green time for the complementary left-turn phase (s), g_r is the effective green time for the phase serving the subject right-turn movement during its permitted period, and all other variables are as previously defined.

The available capacity for the lane group is computed with Equation 31-129.

Equation 31-129

$$c_{a,r,e,pp} = \left(\frac{G_{max,r} s_{rt}}{C} + \frac{g_r s_r}{C} \right) N_r$$

where $c_{a,r,e,pp}$ is the available capacity of an exclusive-lane lane group with protected-permitted right-turn operation (veh/h), and $G_{max,r}$ is the maximum green setting for the phase serving the subject right-turn movement during its permitted period (s).

4. QUEUE STORAGE RATIO

This section discusses queue storage ratio as a performance measure at a signalized intersection. This measure represents the ratio of the back-of-queue size to the available vehicle storage length. The first subsection reviews concepts related to back-of-queue estimation. The second subsection describes a procedure for estimating the back-of-queue size and queue storage ratio.

The discussion in this section describes basic principles for quantifying the back of queue for selected types of lane assignment, lane grouping, left-turn operation, and phase sequence. The analyst is referred to the computational engine for specific calculation details, especially as they relate to assignments, groupings, left-turn operation, and phase sequences not addressed in this section. This engine is described in Section 7.

CONCEPTS

The *back of queue* represents the maximum backward extent of queued vehicles during a typical cycle, as measured from the stop line to the last queued vehicle. The back-of-queue size is typically reached after the onset of the green indication. The point when it is reached occurs just before the most distant queued vehicle begins forward motion as a consequence of the green indication and in response to the forward motion of the vehicle ahead.

A *queued vehicle* is defined as a vehicle that is fully stopped as a consequence of the signal. A *full stop* is defined to occur when a vehicle slows to zero (or a crawl speed, if in queue) as a consequence of the change in signal indication from green to red, but not necessarily in direct response to an observed red indication.

The back-of-queue size that is estimated by the equations described here represents an overall average for the analysis period. It is represented in units of vehicles.

Background

Queue size is defined here to include only fully stopped vehicles. Vehicles that slow as they approach the back of the queue are considered to incur a *partial stop* but are not considered to be part of the queue. The distinction between a full and a partial stop is shown in Exhibit 31-20. This exhibit illustrates the trajectory of several vehicles as they traverse an intersection approach during one signal cycle. There is no residual queue at the end of the cycle.

Each thin line in Exhibit 31-20 that slopes upward from left to right represents the trajectory of one vehicle. The average time between trajectories represents the headway between vehicles (i.e., the inverse of flow rate q). The slope of the trajectory represents the vehicle's speed. The curved portion of a trajectory indicates deceleration or acceleration. The horizontal portion of a trajectory indicates a stopped condition. The effective red r and effective green g times are shown at the top of the exhibit. The other variables shown are defined in the discussion below.

Exhibit 31-20
Time-Space Diagram of Vehicle Trajectory on an Intersection Approach

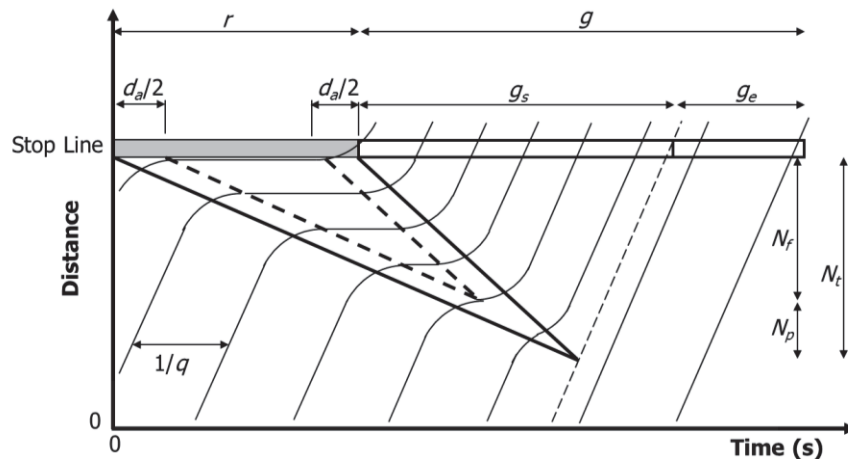

Exhibit 31-20 shows the trajectories of eight vehicles. The first five trajectories (counting from left to right) have a horizontal component to their trajectory that indicates they have reached a full stop as a result of the red indication. The sixth trajectory has some deceleration and acceleration but the vehicle does not stop. This trajectory indicates a partial stop was incurred for the associated vehicle. The last two trajectories do not incur deceleration or acceleration, and the associated vehicles do not slow or stop. Thus, the number of full stops N_f is 5 and the number of partial stops N_p is 1. The total number of stops N_t is 6. The back-of-queue size is equal to the number of full stops.

The back-of-queue size (computed by the procedure described in the next subsection) represents the average back-of-queue size for the analysis period. It is based only on those vehicles that arrive during the analysis period and join the queue. It includes the vehicles that are still in queue after the analysis period ends. The back-of-queue size for a given lane group is computed with Equation 31-130.

Equation 31-130

$$Q = Q_1 + Q_2 + Q_3$$

where

- Q = back-of-queue size (veh/ln),
- Q_1 = first-term back-of-queue size (veh/ln),
- Q_2 = second-term back-of-queue size (veh/ln), and
- Q_3 = third-term back-of-queue size (veh/ln).

The first-term back-of-queue estimate quantifies the queue size described in Exhibit 31-20. It represents the queue caused by the signal cycling through its phase sequence.

The second-term back-of-queue estimate consists of two queue components. One component accounts for the effect of random, cycle-by-cycle fluctuations in demand that occasionally exceed capacity. This fluctuation results in the occasional overflow queue at the end of the green interval (i.e., cycle failure). The second component accounts for queuing due to a sustained oversaturation during the analysis period. This queuing occurs when aggregate demand during the analysis period exceeds aggregate capacity. It is sometimes referred to as the deterministic queue component and is shown as variable $Q_{2,d}$ in Exhibit 31-21.

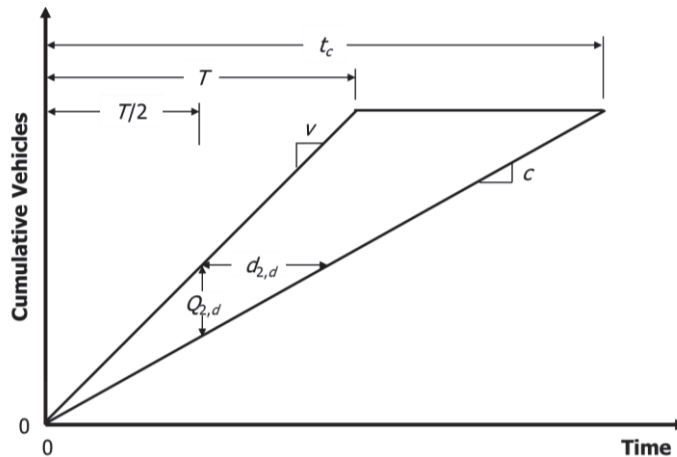

Exhibit 31-21
Cumulative Arrivals and
Departures During an
Oversaturated Analysis Period

Exhibit 31-21 illustrates the queue growth that occurs as vehicles arrive at a demand flow rate v during the analysis period T , which has capacity c . The deterministic delay component is represented by the triangular area bounded by the thick line and is associated with an average delay per vehicle represented by the variable $d_{2,d}$. The average queue size associated with this delay is shown in the exhibit as $Q_{2,d}$. The queue present at the end of the analysis period [$= T(v - c)$] is referred to as the *residual queue*.

The equation used to estimate the second-term queue is based on the assumption that no initial queue is present at the start of the analysis period. The third-term back-of-queue estimate is used to account for the additional queuing that occurs during the analysis period because of an initial queue. This queue is a result of unmet demand in the previous time period. It does *not* include any vehicles that may be in queue due to random, cycle-by-cycle fluctuations in demand that occasionally exceed capacity. When a multiple-period analysis is undertaken, the initial queue for the second and subsequent analysis periods is equal to the residual queue from the previous analysis period.

Exhibit 31-22 illustrates the queue due to an initial queue as a trapezoid shape bounded by thick lines. The average queue is represented by the variable Q_3 . The initial queue size is shown as consisting of Q_b vehicles. The duration of time during the analysis period for which the effect of the initial queue is still present is represented by the variable t . This duration is shown to equal the analysis period in Exhibit 31-22. However, it can be less than the analysis period duration for some lower-volume conditions.

Exhibit 31-22
Third-Term Back-of-Queue
Size with Increasing Queue

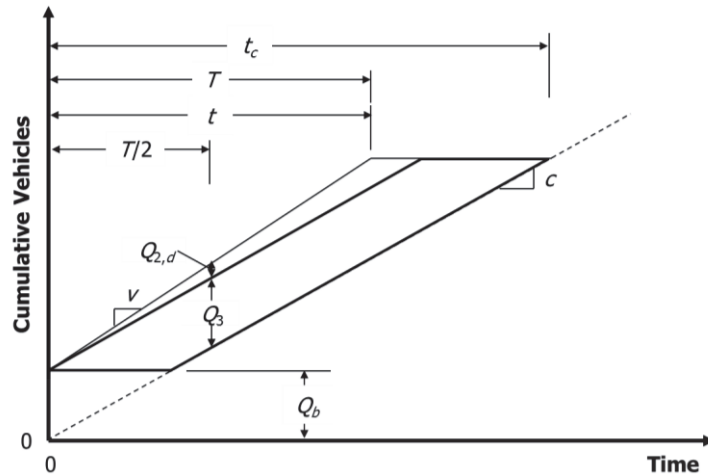

Exhibit 31-22 illustrates the case in which the demand flow rate v exceeds the capacity c during the analysis period. In contrast, Exhibit 31-23 and Exhibit 31-24 illustrate alternative cases in which the demand flow rate is less than the capacity.

Exhibit 31-23
Third-Term Back-of-Queue
Size with Decreasing Queue

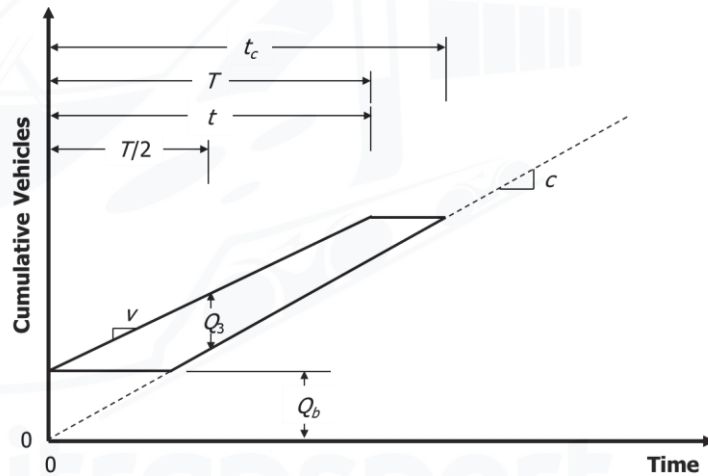
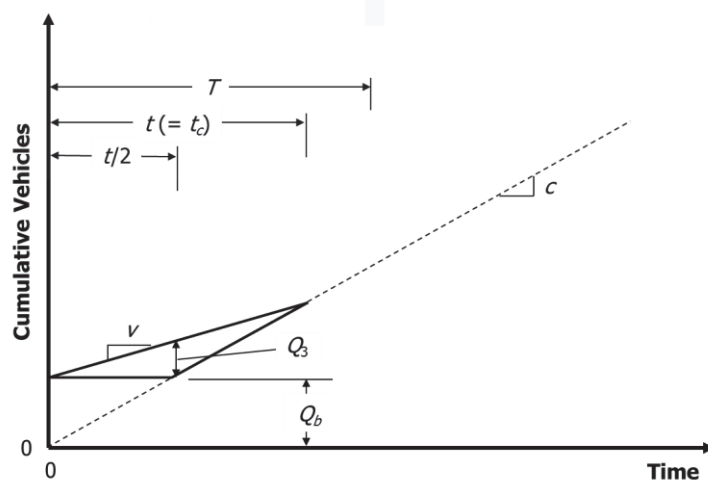

Exhibit 31-24
Third-Term Back-of-Queue
Size with Queue Clearing



In this chapter, *initial queue* is always used in reference to the initial queue due to unmet demand in the previous time period. It *never* refers to vehicles in queue due to random, cycle-by-cycle fluctuations in demand.

Acceleration–Deceleration Delay

The acceleration–deceleration delay d_a term shown in Exhibit 31-20 is used to distinguish between a fully and a partially stopped vehicle. This delay term represents the time required to decelerate to a stop and then accelerate back to the initial speed, less the time it would have taken to traverse the equivalent distance at the initial speed.

Various definitions are used to describe when a vehicle is stopped for the purpose of field measurement. These definitions typically allow the observed vehicle to be called “stopped” even if it has a slow speed (e.g., 2 to 5 mi/h) while moving up in the queue. Many stochastic simulation programs also have a similar allowance. These practical considerations in the count of stopped vehicles require the specification of a threshold speed that can be used to identify when a vehicle is effectively stopped. The acceleration–deceleration delay for a specified threshold speed is estimated with Equation 31-131.

$$d_a = \frac{[1.47 (S_a - S_s)]^2}{2 (1.47 S_a)} \left(\frac{1}{r_a} + \frac{1}{r_d} \right)$$

Equation 31-131

where

d_a = acceleration–deceleration delay (s),

S_a = average speed on the intersection approach (mi/h),

S_s = threshold speed defining a stopped vehicle = 5.0 (mi/h),

r_a = acceleration rate = 3.5 (ft/s²), and

r_d = deceleration rate = 4.0 (ft/s²).

The average speed on the intersection approach S_a is representative of vehicles that would pass unimpeded through the intersection if the signal were green for an extended period. It can be estimated with Equation 31-132.

$$S_a = 0.90 (25.6 + 0.47 S_{pl})$$

Equation 31-132

where S_{pl} is the posted speed limit (mi/h).

The threshold speed S_s represents the speed at or below which a vehicle is said to be effectively stopped while in queue or when joining a queue. The strictest definition of this speed is 0.0 mi/h, which coincides with a complete stop. However, vehicles sometimes move up in the queue while drivers wait for the green indication. A vehicle that moves up in the queue and then stops again does not incur an additional full stop. The threshold speed that is judged to differentiate between vehicles that truly stop and those that are just moving up in the queue is 5 mi/h.

Acceleration–deceleration delay values from Equation 31-131 typically range from 8 to 14 s, with larger values in this range corresponding to higher speeds.

Arrival–Departure Polygon

The arrival–departure polygon (ADP) associated with a lane is a graphic tool for computing the number of full stops N_f . The number of full stops has been shown to be equivalent to the first-term back-of-queue size (5).

The ADP separately portrays the cumulative number of arrivals and departures associated with a traffic movement as a function of time during the average cycle. It is related but not identical to the QAP. The main difference is that the polygon sides in the ADP represent an arrival rate or a discharge rate but not both. In contrast, the polygon sides in the QAP represent the combined arrival and discharge rates that may occur during a common time interval.

The ADP is useful for estimating the stop rate and back-of-queue size, and the QAP is useful for estimating delay and queue service time.

The ADP for a through movement is presented in Exhibit 31-25, which shows the polygon for a typical cycle. The red and green intervals are ordered from left to right in the sequence of presentation so that the last two time periods correspond to the queue service time g_s and green extension time g_e of the subject phase. The variables shown in the exhibit are defined in the following list:

t_f = service time for fully stopped vehicles (s),

N_f = number of fully stopped vehicles (veh/ln),

g_s = queue service time (s),

g_e = green extension time (s),

q_r = arrival flow rate during the effective red time = $(1 - P) q C/r$ (veh/s),

P = proportion of vehicles arriving during the green indication (decimal),

q = arrival flow rate = $v/3,600$ (veh/s),

v = demand flow rate (veh/h),

r = effective red time = $C - g$ (s),

g = effective green time (s),

C = cycle length (s),

q_g = arrival flow rate during the effective green time = $P q C/g$ (veh/s), and

Q_r = queue size at the end of the effective red time = $q_r r$ (veh).

In application, all flow rate variables are converted to common units of vehicles per second per lane. The presentation in this section is based on these units for q and s . If the flow rate q exceeds the lane capacity, then it is set to equal this capacity.

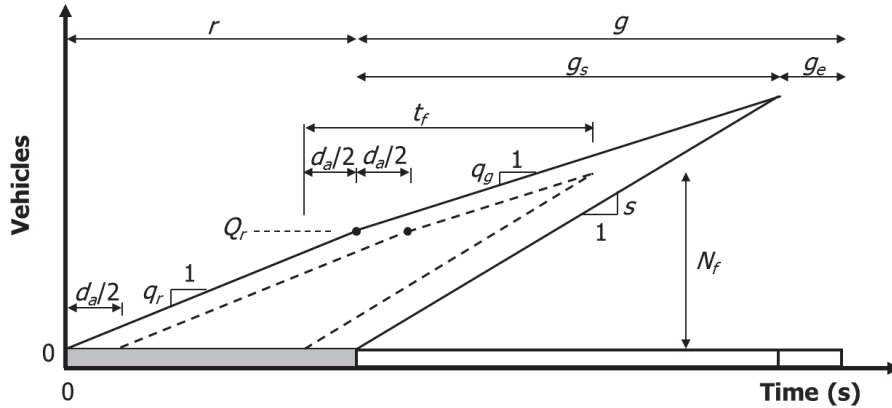

Exhibit 31-25
Arrival-Departure Polygon

The upper solid trend line in Exhibit 31-25 corresponds to vehicles arriving at the intersection. The lower solid trend line corresponds to queued vehicles departing the stop line. The lower trend line is horizontal during the effective red, denoting no departures. The vertical distance between these two lines at any instant in time represents the number of vehicles in the queue.

At the start of the effective red, vehicles begin to queue at a rate of q_r and accumulate to a length of Q_r vehicles at the time the effective green begins. Thereafter, the rate of arrival is q_g until the end of the effective green period. The queue service time g_s represents the time required to serve the queue present at the end of the effective red Q_r plus any additional arrivals that join the queue before it fully clears. The dashed line in this exhibit represents only those vehicles that complete a full stop. The dashed line lags behind the solid arrival line by one-half the value of d_a (i.e., $d_a/2$). In contrast, the dashed line corresponding to initiation of the departure process leads the solid departure line by $d_a/2$.

One-half the acceleration-deceleration delay d_a (i.e., $d_a/2$) occurs at both the end of the arrival process and the start of the discharge process. This assumption is made for convenience in developing the polygon. The derivation of the stop rate and queue length equations indicates that the two components are always combined as d_a . Thus, the assumed distribution of this delay to each of the two occurrences does not influence the accuracy of the estimated back-of-queue size.

The number of fully stopped vehicles N_f represents the number of vehicles that arrive before the queue of stopped vehicles has departed. Equation 31-133 is used for computing this variable (all other variables are as previously defined).

$$N_f = q_r r + q_g (t_f - d_a)$$

Equation 31-133

Equation 31-134 can also be used for estimating N_f .

$$N_f = \frac{s t_f}{3,600}$$

Equation 31-134

Combining Equation 31-133 and Equation 31-134 to eliminate N_f and solve for t_f yields Equation 31-135.

$$t_f = \frac{q_r r - q_g d_a}{s - q_g}$$

Equation 31-135

Equation 31-136

Equation 31-135 can be used with Equation 31-133 to obtain an estimate of N_f . The first-term back-of-queue size is then computed with Equation 31-136.

$$Q_1 = N_f$$

The polygon in Exhibit 31-25 applies to either a through lane group or a left- or right-turn lane group with exclusive lanes operating with the protected mode. Other shapes are possible, depending on whether the lane group includes a shared lane and whether the lane group serves a permitted (or protected-permitted) left-turn movement. In general, a unique shape is dictated by each combination of left-turn operational mode (i.e., permitted, protected, or protected-permitted) and phase sequence (i.e., lead, lag, or split). A general procedure for constructing these polygons is described in the next subsection.

PROCEDURE FOR ESTIMATING BACK OF QUEUE FOR SELECTED LANE GROUPS

This subsection describes a procedure for estimating the back-of-queue size for a lane group at a signalized intersection. The procedure is described in a narrative format and does not define every equation needed to develop a polygon for every combination of lane allocation, left-turn operational mode, and phase sequence. This approach is taken because of the large number of equations required to address the full range of combinations found at intersections in most cities. However, all these equations have been developed and are automated in the computational engine that is described in Section 7. Some of the equations presented in the previous section are repeated in this subsection for reader convenience.

The procedure requires the previous construction of the QAP. The construction of the QAP is described in Section 3.

Step 1. Determine Acceleration–Deceleration Delay

The acceleration–deceleration delay term is used to distinguish between fully and partially stopped vehicles. It is computed with Equation 31-131.

Step 2. Define Arrival–Departure Polygon

During this step, the green times and flow rates used previously to construct the QAP are now used to construct the ADP associated with each lane group served during a phase.

The ADP in Exhibit 31-25 applies to either a through lane group or a left- or right-turn lane group with exclusive lanes operating with the protected mode. This polygon is also applicable to split phasing and to shared lane groups serving through and right-turning vehicles operating with the permitted mode. For split phasing, each approach is evaluated separately to determine its overall stop rate. If the approach has a turn lane, then a separate polygon is constructed for both the turn and the through lane groups.

More complicated combinations of phase sequence and left-turn operational mode dictate more complicated polygons. A polygon must be derived for each combination. The most common combinations are illustrated in Exhibit 31-26 through Exhibit 31-29.

The concept is extended to shared left-turn and through lane groups with protected-permitted operation in Exhibit 31-30 and Exhibit 31-31. Other polygon shapes exist, depending on traffic flow rates, phase sequence, lane use, and left-turn operational mode. The concept of construction must be extended to these other shapes to estimate accurately the back-of-queue size.

Most variables shown in these exhibits were defined in previous subsections. The following variables are also defined:

- g_p = effective green time for permitted left-turn operation (s),
- g_u = duration of permitted left-turn green time that is not blocked by an opposing queue (s),
- g_f = time before the first left-turning vehicle arrives and blocks the shared lane (s),
- g_l = effective green time for left-turn phase (s),
- g_{ps} = queue service time during permitted left-turn operation (s),
- s_p = saturation flow rate of a permitted left-turn movement (veh/h/ln),
- s_{lt} = saturation flow rate of an exclusive left-turn lane with protected operation = s_{th}/E_L (veh/h/ln),
- E_L = equivalent number of through cars for a protected left-turning vehicle = 1.05,
- s_{th} = saturation flow rate of an exclusive through lane (= base saturation flow rate adjusted for lane width, heavy vehicles, grade, parking, buses, and area type) (veh/h/ln), and
- P_L = proportion of left-turning vehicles in the shared lane (decimal).

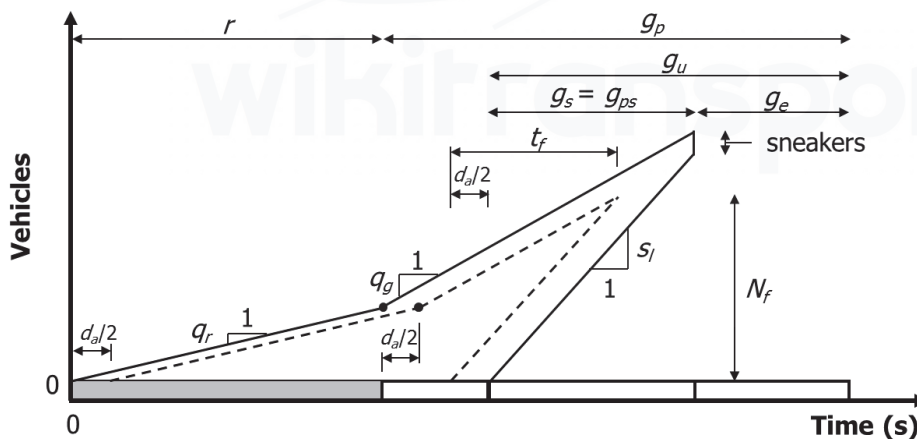

Exhibit 31-26
ADP for Permitted Left-Turn
Operation in an Exclusive
Lane

Exhibit 31-27
ADP for Permitted Left-Turn Operation in a Shared Lane

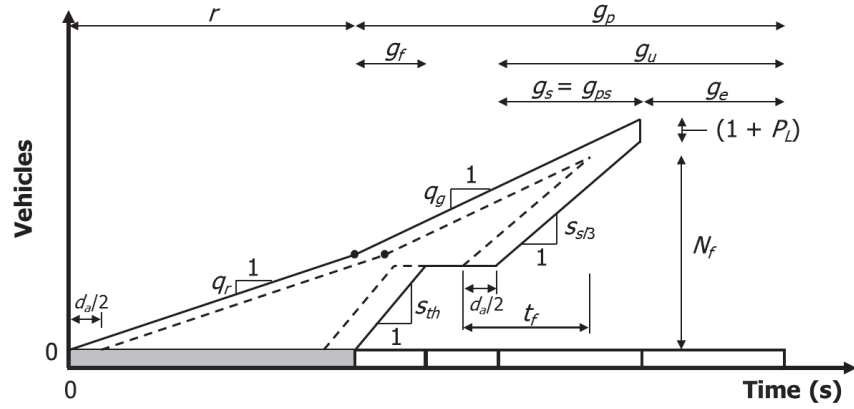

Exhibit 31-28
ADP for Leading, Protected-Permitted Left-Turn Operation in an Exclusive Lane

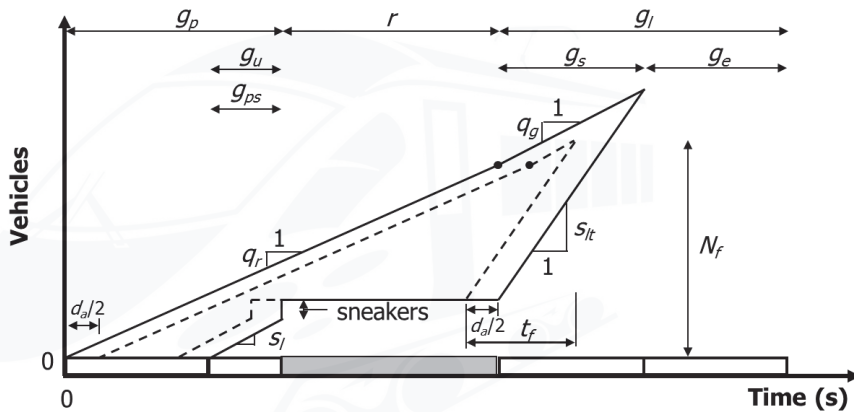
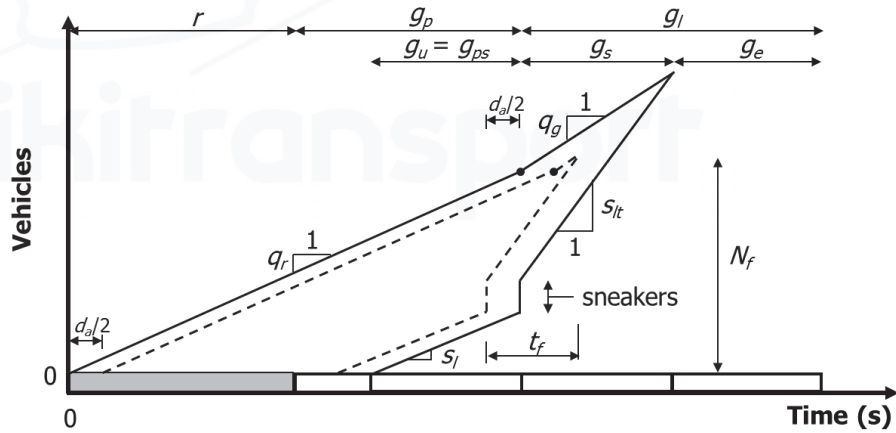

Exhibit 31-29
ADP for Lagging, Protected-Permitted Left-Turn Operation in an Exclusive Lane



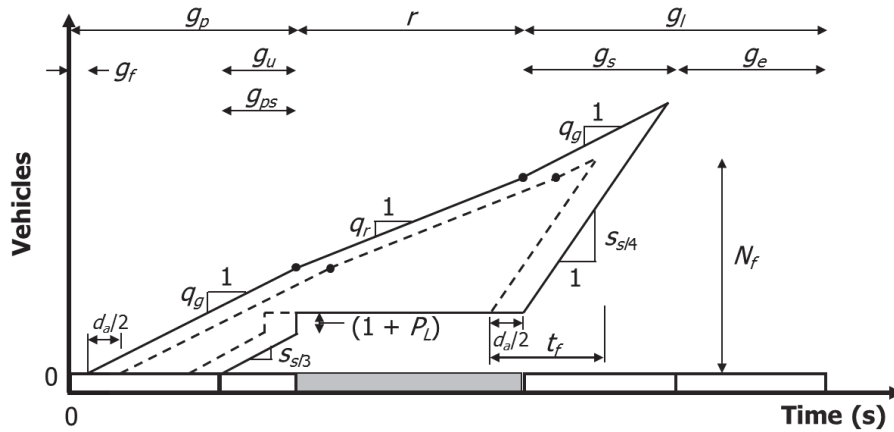

Exhibit 31-30
ADP for Leading, Protected-Permitted Left-Turn Operation in a Shared Lane

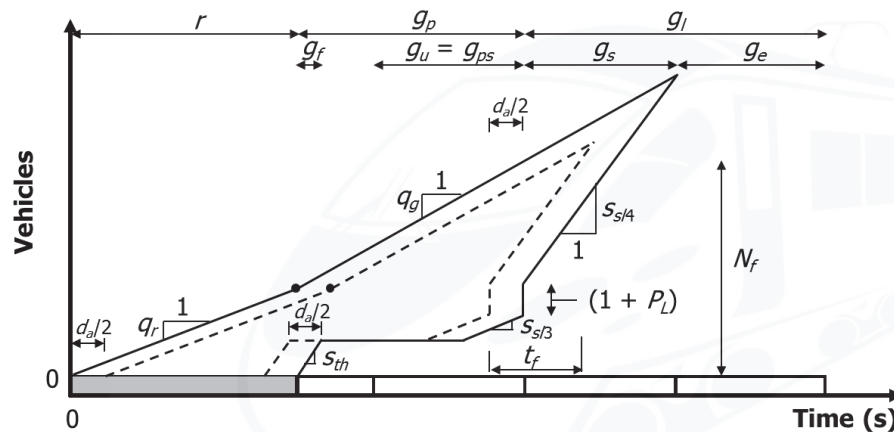

Exhibit 31-31
ADP for Lagging, Protected-Permitted Left-Turn Operation in a Shared Lane

The polygon in Exhibit 31-26 applies to the left-turn lane group served by an exclusive lane that operates in the permitted mode during the adjacent through phase. If the phase extends to max-out, then some left-turning vehicles will be served as sneakers. The expected number of sneakers for this mode is reduced if downstream lane blockage or spillback is present [i.e., sneakers = $n_s f_{ms} f_{sp}$ where n_s is the number of sneakers per cycle = 2.0 (veh), f_{ms} is the adjustment factor for downstream lane blockage, and f_{sp} is the adjustment factor for sustained spillback].

The polygon in Exhibit 31-27 applies to the left-turn and through lane group on a shared-lane approach with permitted operation. If the phase extends to max-out, then some left-turning vehicles will be served as sneakers. The expected number of sneakers (shown as $1 + P_L$) is computed as $(1 + P_L) f_{ms} f_{sp}$ where P_L is the proportion of left-turning vehicles in the shared lane, and all other variables are as previously defined.

The polygon in Exhibit 31-28 applies to left-turn movements that have protected-permitted operation with a leading left-turn phase and an exclusive left-turn lane. The polygon in Exhibit 31-29 applies to the same movements and operation but with a lagging left-turn phase. If a queue exists at the end of the permitted period for either polygon, then the queue is reduced by the number of sneakers (where sneakers = $n_s f_{ms} f_{sp}$).

The polygon in Exhibit 31-30 applies to left-turn movements that have protected-permitted operation with a leading left-turn phase and a shared left-turn and through lane group. The polygon in Exhibit 31-31 applies to the same movements and operation but with a lagging left-turn phase. If a queue exists at the end of the permitted period for either polygon, then the queue is reduced by the expected number of sneakers [which is computed as $(1 + P_L) f_{ms} f_{sp}$].

As noted above, all polygons are based on the requirement that lane volume cannot exceed lane capacity for the purpose of estimating the queue service time. This requirement is met in the polygons shown because the queue size equals 0.0 vehicles at some point during the cycle.

Step 3. Define Arrival–Departure Polygon for Fully Stopped Vehicles

During this step, the polygon defined in the previous step is enhanced to include the polygon shape for the fully stopped vehicles. The fully stopped vehicle polygon is defined by dashed lines in Exhibit 31-25 through Exhibit 31-31.

Two rules guide the development of this polygon feature. First, the dashed line that corresponds to arrivals at the stopped queue *lags* behind the solid arrival line by $d_a/2$ s. Second, the dashed line that corresponds to initiation of the departure process *leads* the solid departure line by $d_a/2$ s.

Step 4. Compute Service Time for Fully Stopped Vehicles

The service time t_f is computed for each polygon constructed in the previous step. When the polygon in Exhibit 31-25 applies, then either Equation 31-137 or Equation 31-138 can be used to compute this time.

If $d_a \leq (1 - P) g X$, then

Equation 31-137

$$t_f = \frac{q C (1 - P - P d_a/g)}{s [1 - \min(1, X) P]}$$

otherwise

Equation 31-138

$$t_f = \frac{q C (1 - P)(r - d_a)}{s [r - \min(1, X) (1 - P)g]}$$

where X is the volume-to-capacity ratio.

The saturation flow rate s used in Equation 31-137 and Equation 31-138 represents the adjusted saturation flow rate that is computed by the procedure described in Section 3 of Chapter 19, Signalized Intersections.

Step 5. Compute the Number of Fully Stopped Vehicles

The number of fully stopped vehicles N_f is computed for each polygon constructed in Step 3. When the polygon in Exhibit 31-25 applies, then Equation 31-139 or Equation 31-140 can be used to compute the number of stops.

If $d_a \leq (1 - P) g X$, then

Equation 31-139

$$N_f = q_r r + q_g (t_f - d_a)$$

otherwise

Equation 31-140

$$N_f = q_r (r - d_a + t_f)$$

Step 6. Compute the First-Term Back-of-Queue Size

The first-term back-of-queue estimate Q_1 (in vehicles per lane) is computed by using the number of fully stopped vehicles from the previous step. It is computed with Equation 31-141, where N_f is the number of fully stopped vehicles.

$$Q_1 = N_f$$

Equation 31-141

For some of the more complex ADPs that include left-turn movements operating with the permitted mode, the queue may dissipate at two or more points during the cycle. If this occurs, then N_{fi} is computed for each of the i periods between queue dissipation points. The first-term back-of-queue estimate is then equal to the largest of the N_{fi} values computed in this manner.

Step 7. Compute the Second-Term Back-of-Queue Size

Equation 31-142 is used to compute the second-term back-of-queue estimate Q_2 for lane groups served by an actuated phase.

$$Q_2 = \frac{c_A}{3,600 N} d_2$$

Equation 31-142

where

Q_2 = second-term back-of-queue size (veh/ln),

c_A = average capacity (veh/h),

d_2 = incremental delay (s/veh), and

N = number of lanes in lane group (ln).

If there is no initial queue, then the average capacity c_A is equal to the lane group capacity c . The procedure for computing this capacity is described in Section 3 of Chapter 19. If there is an initial queue, then the average capacity is computed with the procedure described in Section 4 of Chapter 19.

Step 8. Compute the Third-Term Back-of-Queue Size

The third-term back-of-queue estimate Q_3 is calculated with Equation 31-143 through Equation 31-148.

$$Q_3 = \frac{1}{N T} \left(t_A \frac{Q_b + Q_e - Q_{eo}}{2} \right)$$

Equation 31-143

with

$$Q_e = Q_b + t_A(v - c_A)$$

Equation 31-144

If $v \geq c_A$, then

$$Q_{eo} = T(v - c_A)$$

Equation 31-145

$$t_A = T$$

Equation 31-146

If $v < c_A$, then

$$Q_{eo} = 0.0 \text{ veh}$$

Equation 31-147

$$t_A = Q_b / (c_A - v) \leq T$$

Equation 31-148

where

Q_3 = third-term back-of-queue size (veh/ln),

t_A = adjusted duration of unmet demand in the analysis period (h),

T = analysis period duration (h),

Q_b = initial queue at the start of the analysis period (veh),

Q_e = queue at the end of the analysis period (veh), and

Q_{eo} = queue at the end of the analysis period when $v \geq c_A$ and $Q_b = 0.0$ (veh).

Step 9. Compute the Back-of-Queue Size

The average back-of-queue estimate Q for a lane group (in vehicles per lane) is computed with Equation 31-149 (all other variables are as previously defined).

Equation 31-149

$$Q = Q_1 + Q_2 + Q_3$$

If desired, a percentile back-of-queue estimate $Q_{\%}$ can be computed with Equation 31-150, and Equation 31-151 through Equation 31-153 can be used to compute the percentile back-of-queue factor $f_{B\%}$.

Equation 31-150

$$Q_{\%} = (Q_1 + Q_2)f_{B\%} + Q_3$$

with

If $v \geq c_A$, then

Equation 31-151

$$f_{B\%} = \min \left(1.8, 1.0 + z \sqrt{\frac{I}{Q_1 + Q_2}} + 0.60 z^{0.24} \left(\frac{g}{C}\right)^{0.33} (1.0 - e^{2-2X_A}) \right)$$

Equation 31-152

$$X_A = v/c_A$$

If $v < c_A$, then

Equation 31-153

$$f_{B\%} = \min \left(1.8, 1.0 + z \sqrt{\frac{I}{Q_1 + Q_2}} \right)$$

where

$Q_{\%}$ = percentile back-of-queue size (veh/ln);

$f_{B\%}$ = percentile back-of-queue factor;

z = percentile parameter = 1.04 for 85th percentile queue, 1.28 for 90th percentile queue, and 1.64 for 95th percentile queue;

I = upstream filtering adjustment factor; and

X_A = average volume-to-capacity ratio.

Step 10. Compute Queue Storage Ratio

If the lane group is served by a bay or lane of limited storage length, then the queue storage ratio can be computed by using Equation 31-154 with Equation 31-155.

$$R_Q = \frac{L_h Q}{L_a}$$

Equation 31-154

with

$$L_h = L_{pc}(1 - 0.01 P_{HV}) + 0.01 L_{HV}P_{HV}$$

Equation 31-155

where

R_Q = queue storage ratio,

L_a = available queue storage distance (ft/ln),

L_h = average vehicle spacing in stationary queue (ft/veh),

L_{pc} = stored passenger car lane length = 25 (ft),

L_{HV} = stored heavy-vehicle lane length = 45 (ft), and

P_{HV} = percentage heavy vehicles in the corresponding movement group (%).

Average vehicle spacing is the average length between the front bumpers of two successive vehicles in a stationary queue. The available queue storage distance is equal to the turn bay (or lane) length.

The queue storage ratio is useful for quantifying the potential blockage of the available queue storage distance. If the queue storage ratio is less than 1.0, then blockage will not occur during the analysis period. Blockage will occur if the queue storage ratio is equal to or greater than 1.0.

If desired, a percentile queue storage ratio can be computed with Equation 31-156.

$$R_{Q\%} = \frac{L_h Q\%}{L_a}$$

Equation 31-156

where $R_{Q\%}$ is the percentile queue storage ratio.

5. PLANNING-LEVEL ANALYSIS APPLICATION

The planning-level analysis application described in this section is intended to provide the user a means for conducting a simplified and approximate analysis of signalized intersection operations for motorized vehicles. Chapter 19, Signalized Intersections, provides a more detailed methodology. The objective of the planning-level analysis application is to assess whether an intersection's geometric conditions are sufficient to handle the projected demand volume. Within this framework, many of the data required for a full operational analysis are not needed. This method has several potential uses and applications:

- Conducting sketch-level analyses to quickly assess whether an intersection's lane geometry is sufficient to accommodate a given set of turn-movement demand volumes;
- Evaluating intersection geometry and lane widening alternatives;
- Estimating signal phasing and timing;
- Comparing analysis results against traffic operational performance results produced by other methods; and
- Educating students, transportation professionals, and nontransportation professionals about the fundamentals of traffic signal operational performance.

OVERVIEW OF THE APPLICATION

This subsection provides an overview of the two parts of the planning-level analysis application. Part I provides an estimate of intersection capacity sufficiency. Part II extends the analysis from Part I to provide an estimate of delay and level of service (LOS).

The planning-level analysis application is designed to evaluate the performance of designated groups of lanes, an intersection approach, and the entire intersection. A group of lanes designated for separate analysis is referred to as a *lane group*. Lane groups form the basis for intersection analysis in the planning-level analysis application and in the motorized vehicle methodology described in Chapter 19. However, the criteria for defining a lane group are different between the two methodologies.

For the planning-level analysis application, all traffic movements for a given approach (i.e., left, through, and right) must be assigned to at least one lane group. A lane group can consist of one or more lanes. There are two guidelines to follow for assigning traffic movements to lane groups:

1. When a traffic movement uses only an exclusive lane (or lanes), it is analyzed as an exclusive lane group.
2. When two or more traffic movements share a lane, all lanes that convey those traffic movements are analyzed as a mixed lane group.

When a right-turn movement is shared with a through movement, it is considered to be a part of the through movement lane group. When a right-turn movement is shared with a left-turn movement (such as at a T-intersection), it is

considered to be a part of the left-turn movement lane group. The concept of lane group is discussed in more detail in the Methodology subsection.

Part I: Intersection Sufficiency Assessment

Part I provides an estimate of the intersection's volume-to-capacity ratio, which can be used to assess whether the intersection is likely to operate under, near, or over capacity during the analysis period. This assessment is predicated on the critical movement analysis technique developed originally as part of *Transportation Research Circular 212 (6)*.

Part I generally requires only two inputs: turn movement volume and lane geometry. Other input data are allowed, but they can also be set to default values if they are not explicitly known. Part I can be applied by using manual calculations; it does not require software to implement.

Part I consists of the following steps:

1. Determine left-turn operation.
2. Convert movement volumes to through passenger-car equivalents.
3. Assign flow rates to lane groups.
4. Determine critical lane groups.
5. Determine intersection sufficiency.

Part II: Delay and Level of Service Assessment

Part II extends the results from Part I to produce estimates of volume-to-capacity ratio, delay, and LOS. For practical purposes, Part II requires a spreadsheet or other software to compute estimates of delay and LOS. A Part II analysis requires the initial completion of Steps 1 to 5 of Part I. It then continues with the following steps:

6. Calculate capacity.
7. Determine delay and LOS.

Limitations

The planning-level analysis application has the following limitations:

- It only considers the performance of motorized vehicles;
- It is based on pretimed operation and thus does not account for the effects of actuated control;
- It does not analyze all potential combinations of left-turn operation for opposing approaches (e.g., protected left-turn operation opposed by permitted left-turn operation is not addressed by the application);
- It does not explicitly consider the effects of poorly timed signals;
- It does not account for upstream or downstream impedances and effects of short lanes; and
- It does not consider the effects of grade, lane width, bus activity, area type, pedestrian-vehicle conflicts, or pedestrian-bicycle conflicts;

however, an “equivalency factor for other conditions” is provided to allow the analyst to account for these (or other) nonideal conditions.

REQUIRED DATA AND SOURCES

Exhibit 31-32 describes the input data requirements for conducting an analysis using the planning-level analysis application.

Exhibit 31-32
Required Input Data for the
Planning-Level Analysis
Application

Data Item	Comments
<i>Part I</i>	
Number of lanes and lane use	Required. Exclusive or shared lane use.
Turn movement volumes	Required
Intersection peak hour factor	Use default value of 0.92 if not known.
Percentage heavy vehicles	Use default value of 3% if not known.
On-street parking presence	No (default)
Level of pedestrian activity	None (default) Low – 50 p/h Medium – 200 p/h High – 400 p/h Extreme – 800 p/h
Left-turn operation and phase sequence	Protected operation—with left-turn phase Permitted operation—no left-turn phase Protected operation—split phasing Protected-permitted operation—with left-turn phase (Can be estimated—use guidance provided in the application)
Base saturation flow rate	(Can be estimated—use guidance provided in the application)
Cycle length	(Can be estimated—use guidance provided in the application)
Effective green time	Required to evaluate protected-permitted operation, if present (Can be estimated—use guidance provided in the application)
<i>Part II</i>	
Effective green time	(Can be estimated—use guidance provided in the application)
Progression quality	Good progression Random arrivals (default) Poor progression

The analyst is required to specify values for two data items: (a) the volume for each movement and (b) the number of lanes (and the turn designation for each lane) on each approach. The effective green time is also required if protected-permitted left-turn operation is to be evaluated. Default values can be assumed for the other input data, or the user can specify these values if they are known.

METHODOLOGY

Part I: Intersection Sufficiency Assessment

The first part of the application consists of five steps. These steps are completed in sequence to evaluate the capacity sufficiency of the intersection.

Step 1: Determine Left-Turn Operation

For approaches with left-turn movements, the left-turn operational mode and phase sequence must be defined. The following mode and sequence combinations are addressed in the planning-level analysis application:

- **Protected operation— with left-turn phase.** This combination enables the subject left-turn movement to proceed concurrently with either the adjacent through movement or the opposing left-turn movement.

- **Permitted operation—no left-turn phase.** This combination enables the subject left-turn movement to proceed through the intersection during the same phase indication as the opposing through movement. It generally results in higher capacity for the intersection than other combinations. However, it also produces the highest potential safety conflicts.
- **Protected operation—split phasing.** With split phasing, the through and left-turn movements on the subject approach are served in a protected manner during a common phase. This combination is generally the least efficient type of operation and is oftentimes used when geometric properties of the intersection preclude movements on opposing approaches from proceeding at the same time, or when traffic volumes on opposite approaches are unbalanced.
- **Protected-permitted operation—with left-turn phase.** This combination serves left turns in a protected manner during a left-turn phase and in a permitted manner during a through phase. If this combination is to be evaluated, the analyst should refer to the supplemental procedure in the Protected-Permitted Left-Turn Operations section.

If the operational mode is not known, the following general rules can be applied to determine if protected operation is appropriate for planning-level analysis purposes. Protected operation should be assumed if any of the following conditions are met:

1. The left-turn volume is greater than or equal to 240 veh/h.
2. The product of the left-turn volume and the opposing through volume exceeds a given threshold (50,000 if there is one opposing through lane, 90,000 if there are two opposing through lanes, and 110,000 if there are three or more opposing through lanes).
3. There is more than one left-turn lane on the approach.

Several other considerations for choosing a left-turn operation are not considered to be an explicit part of a planning method. The *Traffic Engineering Handbook* (7) provides additional criteria that include the speed of vehicles on the opposing approach, restrictive sight distances, and accident rates, among others. Therefore, protected left-turn operation may be appropriate even when the above conditions are not satisfied.

In some cases, an intersection may have protected left-turn operation on one approach and permitted left-turn operation on the opposite approach. When this situation occurs, it is necessary to assume both approaches have protected operation to use the planning-level analysis application.

Step 2: Convert Movement Volumes to Through Passenger-Car Equivalents

The objective of this step is to convert all movement volumes into through passenger-car equivalents. The conversion considers one or more of the following factors:

- Effect of heavy vehicles,
- Variation in flow during the hour,

- Impact of opposing through vehicles on permitted left-turn vehicles,
- Impact of pedestrians on right-turn vehicles,
- Impact of parking maneuvers, and
- Lane utilization.

Equation 31-157 provides the volume adjustment equation. Each of the factors in this equation is described in the subsequent paragraphs.

Equation 31-157

$$v_{adj} = V E_{HV} E_{PHF} E_{LT} E_{RT} E_p E_{LU} E_{other}$$

where

v_{adj} = equivalent through movement flow rate expressed in through passenger cars per hour (tpc/h),

V = movement volume (veh/h),

E_{HV} = equivalency factor for heavy vehicles,

E_{PHF} = equivalency factor for peaking characteristics,

E_{RT} = equivalency factor for right turns,

E_{LT} = equivalency factor for left turns,

E_p = equivalency factor for parking activity,

E_{LU} = equivalency factor for lane utilization, and

E_{other} = equivalency factor for other conditions.

Adjustment for Heavy Vehicles

The equivalency factor to convert the mixed traffic stream into passenger car equivalents is computed with Equation 31-158.

Equation 31-158

$$E_{HV} = 1 + 0.01 P_{HV} (E_T - 1)$$

where

P_{HV} = percentage of heavy vehicles in the corresponding lane group (%), and

E_T = equivalent number of through cars for each heavy vehicle = 2.0.

The recommended passenger car equivalent E_T in this method is 2.0. If the user has more detailed or localized information about the value of E_T , then this value may be used in Equation 31-158.

Adjustment for Variation in Flow During the Hour

The movement volume is adjusted by the peak hour factor to reflect the peak 15-min flow rate, similar to the procedure used in the operational method. Equation 31-159 is used to compute the peak hour adjustment factor.

Equation 31-159

$$E_{PHF} = \frac{1}{PHF}$$

where PHF is the peak hour factor (varies between 0.25 and 1.00).

Adjustment for Impedances Experienced by Turning Vehicles

The equivalency factors used to account for impedances experienced by left- and right-turn movements are shown in Exhibit 31-33 and Exhibit 31-34.

Left-Turn Operation	Total Opposing Volume V_o (veh/h) ^a	Equivalency Factor for Left Turns E_{LT}
Protected—with left-turn phase	Any	1.05
Protected—split phasing		
Permitted—no left-turn phase	<200	1.1
	200–599	2.0
	600–799	3.0
	800–999	4.0
	≥1,000	5.0
Protected-permitted—with left-turn phase	Refer to guidance in the Protected-Permitted Left-Turn Operations section	

Note: ^a Includes the sum of through and right-turn volumes on the opposing approach, regardless of whether the right-turn volume is served in an exclusive right-turn lane.

Level of Pedestrian Activity	Pedestrian Volume (p/h)	Equivalency Factor for Right Turns E_{RT}
None or low	0–199	1.2
Moderate	200–399	1.3
High	400–799	1.5
Extreme	≥800	2.1

In Exhibit 31-33, the equivalency factor that is applicable to permitted left-turn movements is based on the opposing volume. This volume is defined as the sum of opposing through and right-turn movements, regardless of whether the right-turn volume is served in an exclusive right-turn lane. The equivalency factor for right turns is a function of the pedestrian activity in the crosswalk that conflicts with the subject right-turn movement.

Adjustment for Parking Activity

The equivalency factor for on-street parking activity is shown in Exhibit 31-35. This factor is applicable to through and right-turn vehicles. It is also applicable to left-turn vehicles on a one-way street when parking is allowed on the left side.

On-Street Parking Presence	No. of Lanes in Lane Group	Equivalency Factor for Parking Activity E_p
No	All	1.00
Yes	1	1.20
	2	1.10
	3	1.05

Adjustment for Lane Utilization

The planning-level analysis application analyzes the performance of the heaviest-traveled lane. For lane groups with two or more lanes, the volume is adjusted to reflect the heaviest-traveled lane. The appropriate equivalency factor to account for lane utilization is selected from Exhibit 31-36.

Exhibit 31-33
Planning-Level Analysis:
Equivalency Factor for Left Turns

Exhibit 31-34
Planning-Level Analysis:
Equivalency Factor for Right Turns

Exhibit 31-35
Planning-Level Analysis:
Equivalency Factor for Parking Activity

Exhibit 31-36
 Planning-Level Analysis:
 Equivalency Factor for Lane
 Utilization

Lane Group Movement	No. of Lanes in Lane Group	Equivalency Factor for Lane Utilization E_{LU}
Through or shared	1	1.00
	2	1.05
	≥ 3	1.10
Exclusive left turn	1	1.00
	≥ 2	1.03
Exclusive right turn	1	1.00
	≥ 2	1.13

Adjustment for "Other" Conditions

An adjustment factor for "other" is provided in Equation 31-157. This factor is a placeholder to allow the user to further adjust the movement volume for conditions that are not captured by any other adjustment factor. The analyst may apply any combination of the saturation flow rate adjustment factors presented in Section 3 of Chapter 19 to reflect other nonideal conditions. In this situation, E_{other} is computed as the product of the inverted factors (i.e., $E_{other} = 1/f_i \times 1/f_j \times \dots \times 1/f_w$ where f_i , f_j , and f_n represent the factors in Chapter 19 that are applicable to the subject movement).

Step 3: Assign Flow Rates to Lane Groups

Initially, lane groups should be checked to determine if a de facto turn lane exists. A de facto turn lane occurs on approaches with multilane lane groups where (a) either a left- or right-turn movement is shared with a through movement and (b) the turning flow rates are sufficiently high, or the impedance to the turning traffic is sufficiently great, to reasonably expect that the through vehicles use only the adjacent exclusive through lane(s) and avoid the shared lane.

The presence of a de facto turn lane can be determined by comparing the total flow rate of turning traffic (left or right) with the lane-equivalent adjusted flow rate in the shared lane as calculated in Step 2. If the flow rate of turning traffic is greater than the lane-equivalent adjusted flow rate, a de facto turn lane should be assumed. De facto turn lanes should be analyzed as exclusive turn lanes, and thus all through movements should be assigned to the through-only lane(s).

In cases in which there are multiple turn lanes and one lane is shared with a through movement, these lanes should be treated as a single lane group that is designated as the through lane group. For approaches at a T-intersection where there are only left- and right-turn movements and multiple lanes, and one of the lanes is shared, the user has the option of coding all lanes as either the right-turn lane group or the left-turn lane group.

Once lane groups have been defined, the lane group flow rate is divided by the number of lanes associated with the lane group to obtain the lane flow rate. Equation 31-160 is used for this purpose.

$$v_i = \frac{v_{adj,i}}{N_i}$$

where

v_i = lane flow rate for lane group i expressed in through passenger cars per hour per lane (tpc/h/ln);

Equation 31-160

$v_{adj,i}$ = equivalent through movement flow rate for lane group i (tpc/h); and

N_i = number of lanes associated with lane group i , accounting for de facto lanes (ln).

Step 4: Determine Critical Lane Groups

The critical lane groups are identified and the sum of critical-lane flow rates is determined in this step. Critical lane groups represent the unique combination of conflicting lane groups that have the highest total flow rate. These critical lane groups dictate the amount of green time required during each phase. They also dictate the total cycle length required for the intersection. The critical lane groups for the north–south and east–west approaches are assessed independently.

This step consists of three tasks. During the first task, the right-turn flow rate is adjusted to account for right-turn capacity during the complementary left-turn phase. During the second task, the critical lane groups are identified. During the third task, the critical-lane group flow rates are added to determine the sum of critical-lane flow rates.

Step 4a. Adjust Right-Turn Flow Rate

There may be situations in which an exclusive right-turn lane could have a higher flow rate than the adjacent through lane(s). In this situation, the right turns that could occur simultaneously with a protected left-turn movement from the cross street should be deducted from the right-turn flow rate. For example, if the exclusive northbound right-turn flow rate is 300 tpc/h/ln and the protected westbound left-turn flow rate is 125 tpc/h/ln, 125 northbound right-turn vehicles should be assumed to depart the intersection during the westbound left-turn phase. Thus, 125 should be deducted from the total northbound right-turn flow rate, resulting in an adjusted northbound right-turn flow rate of 175 tpc/h/ln. This adjustment is only necessary when the right-turn lane group is critical. If that is the case, the rules described in Step 4b should replace the through lane group flow rate with the right-turn lane group flow rate.

Step 4b. Identify Critical Lane Groups

The lane groups that are determined to be critical are identified in this task. The rules for making this determination are dependent on the left-turn operational mode and phase sequence. Each of the combinations addressed by the planning-level analysis application is discussed in the following paragraphs.

Protected operation—with left-turn phase. When opposing approaches use protected left-turn operation, there are two possible lane group combinations that could determine the critical-lane flow rate. Each combination comprises a left-turn lane group and its opposing through (or right-turn) lane group. The flow rate for each lane group pair is added. The maximum of these two sums defines the critical-lane flow rate. For the east–west approaches, the critical-lane flow rate is computed with Equation 31-161.

Equation 31-161

$$V_{c,prot,1} = \max \begin{bmatrix} v_{EBlt} + v_{WBth} \\ v_{WBlt} + v_{EBth} \end{bmatrix}$$

where

$V_{c,prot,1}$ = critical-lane flow rate for protected left-turn operation on the east–west approaches (tpc/h/ln), and

v_i = lane flow rate for lane group i ($i = EBlt$: eastbound left turn, $WBlt$: westbound left turn, $EBth$: eastbound through, $WBth$: westbound through) (tpc/h/ln).

The two lane groups that add to produce the largest critical-lane flow rate in Equation 31-161 represent the critical lane groups for the east–west street.

Similarly, for north–south approaches with protected left-turn operation, the critical-lane flow rate is computed with Equation 31-162.

Equation 31-162

$$V_{c,prot,2} = \max \begin{bmatrix} v_{NBlt} + v_{SBth} \\ v_{SBlt} + v_{NBth} \end{bmatrix}$$

where

$V_{c,prot,2}$ = critical-lane flow rate for protected left-turn operation on the north–south approaches (tpc/h/ln), and

v_i = lane flow rate for lane group i ($i = NBlt$: northbound left turn, $SBlt$: southbound left turn, $NBth$: northbound through, $SBth$: southbound through) (tpc/h/ln).

The two lane groups that add to produce the largest critical-lane flow rate in Equation 31-162 represent the critical lane groups for the north–south street.

Permitted operation—no left-turn phase. When opposing approaches use permitted operation, the critical-lane flow rate will be the highest lane flow rate of all lane groups associated with the pair of approaches. For the east–west approaches, the critical-lane flow rate is computed with Equation 31-163.

Equation 31-163

$$V_{c,perm,1} = \max (v_{EBlt}, v_{EBth}, v_{EBrt}, v_{WBlt}, v_{WBth}, v_{WBrt})$$

where

$V_{c,perm,1}$ = critical-lane flow rate for permitted left-turn operation on the east–west approaches (tpc/h/ln), and

v_i = lane flow rate for lane group i ($i = EBlt$: eastbound left turn, $WBlt$: westbound left turn, $EBth$: eastbound through, $WBth$: westbound through, $EBrt$: eastbound right turn, $WBrt$: westbound right turn) (tpc/h/ln).

The lane group that produces the largest critical-lane flow rate in Equation 31-163 represents the critical lane group for the east–west street.

Similarly, for north–south approaches with permitted left-turn operation, the critical-lane flow rate is computed with Equation 31-164.

Equation 31-164

$$V_{c,perm,2} = \max (v_{SBlt}, v_{SBth}, v_{SBrt}, v_{NBlt}, v_{NBth}, v_{NBrt})$$

where

$V_{c,perm,2}$ = critical-lane flow rate for permitted left-turn operation on the north-south approaches (tpc/h/ln), and

v_i = lane flow rate for lane group i ($i = SBlt$: southbound left turn, $NBlT$: northbound left turn, $SBth$: southbound through, $NBth$: northbound through, $SBrt$: southbound right turn, $NBrt$: northbound right turn) (tpc/h/ln).

The lane group that produces the largest critical-lane flow rate in Equation 31-164 represents the critical lane group for the north-south street.

Protected operation—split phasing. When opposing approaches use split phasing (i.e., when only one approach is served during a phase), the critical-lane flow rate for a given approach will be the highest lane flow rate of all lane groups for that approach. The critical-lane flow rate for the two opposing approaches will be the sum of the highest lane flow rate for each approach. For the east-west approaches, the critical-lane flow rate is computed with Equation 31-165.

$$V_{c,split,1} = \max(v_{EBlt}, v_{EBth}, v_{EBrt}) + \max(v_{WBlt}, v_{WBth}, v_{WBrt})$$

Equation 31-165

where $V_{c,split,1}$ is the critical-lane flow rate for split phasing on the east-west approaches (tpc/h/ln).

The two lane groups that add to produce the largest critical-lane flow rate in Equation 31-165 represent the critical lane groups for the east-west street.

Similarly, for the north-south approaches with split phasing, the critical-lane flow rate is computed with Equation 31-166.

$$V_{c,split,2} = \max(v_{SBlt}, v_{SBth}, v_{SBrt}) + \max(v_{NBlT}, v_{NBth}, v_{NBrt})$$

Equation 31-166

where $V_{c,split,2}$ is the critical-lane flow rate for split phasing on the north-south approaches (tpc/h/ln).

The two lane groups that add to produce the largest critical-lane flow rate in Equation 31-166 represent the critical lane groups for the north-south street.

Protected-permitted operation—with left-turn phase. If protected-permitted operation is to be evaluated, the analyst should refer to the supplemental procedure in the Protected-Permitted Left-Turn Operations subsection.

Step 4c. Calculate the Sum of Critical-Lane Flow Rates

Once the critical lane groups have been identified, the sum of critical-lane flow rates for the intersection can be computed by adding the lane flow rate associated with each critical lane group. Alternatively, the sum of critical-lane flow rates can be computed by adding the critical-lane group flow rate for each intersecting street, as calculated in the previous task. The following four cases illustrate this technique for some example combinations of left-turn operation and phase sequence using Equation 31-167 through Equation 31-170.

Case 1: East-west and north-south approaches use protected operation—with left-turn phase.

$$V_c = V_{c,prot,1} + V_{c,prot,2}$$

Equation 31-167

where V_c is the sum of the critical-lane flow rates (tpc/h/ln).

Case 2: East–west and north–south approaches use permitted operation—no left-turn phase.

Equation 31-168

$$V_c = V_{c,perm,1} + V_{c,perm,2}$$

Case 3: East–west approaches use protected operation—with left-turn phase and north–south approaches use permitted operation—no left-turn phase.

Equation 31-169

$$V_c = V_{c,prot,1} + V_{c,perm,2}$$

Case 4: East–west approaches use protected operation—with left-turn phase and north–south approaches use protected operation—split phasing.

Equation 31-170

$$V_c = V_{c,prot,1} + V_{c,split,2}$$

Step 4d. Identify Critical Phases

The critical phases identified in this task are used in Part II. If Part II is not part of the analysis, then this task can be skipped.

For this task, one critical phase is associated with each critical lane group, as identified in Step 4b. The flow rate that corresponds to a critical lane group (and critical phase i) is called the critical-lane flow rate $v_{c,i}$. By definition, the sum of these critical-lane flow rates equals the sum of critical-lane flow rates V_c .

For example, consider an intersection for which Equation 31-167 is determined to be applicable (i.e., the intersection has protected operation—with left-turn phase on both approaches). If the eastbound left-turn and westbound through phases are found to yield the critical-lane flow rate $V_{c,prot,1}$, then the eastbound left-turn phase and the westbound through phase are identified as critical phases. The critical-lane flow rates for the east–west approaches are $v_{c,EBlt}$ ($= v_{EBlt}$) and $v_{c,WBth}$ ($= v_{WBth}$).

Step 5: Determine Intersection Sufficiency

This step consists of four tasks. The first task is to determine the cycle length, and the second is to calculate intersection capacity. The third task is to compute the intersection volume-to-capacity ratio. The fourth task is to determine whether the intersection is operating under, near, or over its capacity.

If local data describing cycle length and base saturation flow rate are not available, then a default intersection capacity c_l of 1,650 tpc/h/ln can be used. This default value reflects a base saturation flow rate of 1,900 pc/h/ln, a lost time of 4.0 s per phase, and a cycle length equal to 30 s per critical phase. If the default intersection capacity is used, then the analyst can proceed to Step 5c.

Step 5a. Calculate Cycle Length

If cycle length is known, then the analyst can proceed to Step 5b.

For purposes of conducting a planning-level analysis, the analyst can assume a cycle length equal to 30 s for each critical phase. For example, an intersection with a protected left-turn phase for each of the eastbound and westbound approaches and permitted left-turn operation for the northbound and southbound approaches could be assumed to have a 90-s cycle length. The selection of a cycle length in practice should be based on consideration of

multiple factors including (a) local agency policies and practices and (b) needs of nonmotorized users.

Step 5b. Calculate Intersection Capacity

Intersection capacity is calculated with Equation 31-171.

$$c_I = s_o \frac{C - (n_{cp} l_t)}{C}$$

Equation 31-171

where

c_I = intersection capacity (tpc/h/ln),

s_o = base saturation flow rate (pc/h/ln),

C = cycle length (s),

n_{cp} = number of critical phases, and

l_t = phase lost time (s).

A default phase lost time of 4.0 s for each critical phase is recommended. A default value for base saturation flow rate can be obtained from Exhibit 19-11.

Step 5c. Calculate the Intersection Volume-to-Capacity Ratio

The critical intersection volume-to-capacity ratio is calculated with Equation 31-172.

$$X_c = \frac{V_c}{c_I}$$

Equation 31-172

where

X_c = critical intersection volume-to-capacity ratio,

V_c = sum of critical-lane flow rates (tpc/h/ln), and

c_I = intersection capacity (tpc/h/ln).

Step 5d. Assess Intersection Sufficiency

The objective of this task is to assess the sufficiency of the intersection in terms of its ability to accommodate a given demand level. Exhibit 31-37 provides guidance for determining whether an intersection is operating under, near, or over its available capacity.

The analyst may stop at this point or may continue with Part II to determine delay and LOS.

Exhibit 31-37
 Planning-Level Analysis:
 Intersection Volume-to-
 Capacity Ratio Assessment
 Levels

Critical Intersection Volume-to-Capacity Ratio	Description	Capacity Assessment
<0.85	All demand is able to be accommodated; delays are low to moderate.	Under
0.85–0.98	Demand for critical lane groups is near capacity and some lane groups require more than one cycle to clear the intersection; all demand is able to be processed within the analysis period; delays are moderate to high.	Near
>0.98	Demand for critical lane groups is just able to be accommodated within a cycle but often requires multiple cycles to clear the intersection; delays are high and queues are long.	Over

Part II: Delay and Level of Service

Part II builds on the results of Part I by allowing the user to calculate capacity, delay, and LOS.

Step 6: Calculate Capacity

This step consists of two tasks. For the first task, the analyst calculates the effective green time for each critical phase. For the second task, the analyst calculates the volume-to-capacity ratio for each lane group.

Step 6a. Calculate Effective Green Times

If the effective green time for each critical phase is known, then the analyst can proceed to Step 6b.

The total effective green time available for all critical phases is equal to the cycle length minus the total lost time per cycle. This calculation is shown in Equation 31-173.

Equation 31-173

$$g_{tot} = C - (n_{cp}l_t)$$

where

- g_{tot} = total effective green time in the cycle (s),
- C = cycle length (s),
- n_{cp} = number of critical phases, and
- l_t = phase lost time (s).

A default phase lost time of 4.0 s for each critical phase is recommended.

The total effective green time is allocated to each critical phase in proportion to the lane flow rate for each critical phase. Equation 31-174 is used to compute the effective green time for a given critical lane group.

Equation 31-174

$$g_{c,i} = g_{tot} \left(\frac{v_{c,i}}{V_c} \right)$$

where

- $g_{c,i}$ = effective green time for critical lane group i (s),
- g_{tot} = total effective green time in the cycle (s),

$v_{c,i}$ = lane flow rate for critical lane group i (tpc/h/ln), and

V_c = sum of the critical-lane flow rates (tpc/h/ln).

The effective green time for a noncritical lane group is set equal to the effective green time for its counterpart critical lane group that occurs concurrently during the same phase.

Finally, the effective green time g_i for each phase i is set equal to the effective green time that is computed for the corresponding lane group. The effective green time computed in this manner should be reviewed against policy requirements and other considerations (such as the minimum green time based on driver expectancy and the time required for pedestrians to cross the approach).

Step 6b. Calculate Capacity and Volume-to-Capacity Ratios

The lane group capacity and volume-to-capacity ratio can be computed with Equation 31-175 and Equation 31-176, respectively.

$$c_i = s_o N_i \frac{g_i}{C}$$

Equation 31-175

$$X_i = \frac{N_i v_i}{c_i}$$

Equation 31-176

where

c_i = capacity of lane group i (tpc/h);

g_i = effective green time for lane group i (s);

N_i = number of lanes associated with lane group i , accounting for de facto lanes (ln);

X_i = volume-to-capacity ratio for lane group i ;

v_i = lane flow rate for lane group i (tpc/h/ln); and

C = cycle length (s).

The capacity for each lane group is based on the base saturation flow rate s_o . A default value for base saturation flow rate can be obtained from Exhibit 19-11. This rate is not adjusted for parking activity, heavy vehicles, and so forth because these adjustments are applied in Step 2 to the lane group flow rate.

Equation 31-177 and Equation 31-178 can be used to compute the intersection capacity and intersection volume-to-capacity ratio, respectively.

$$c_{\text{sum}} = s_o \frac{\sum_{i=1}^{n_{cp}} g_{c,i}}{C}$$

Equation 31-177

$$X_c = \frac{V_c}{c_{\text{sum}}}$$

Equation 31-178

where c_{sum} is the intersection capacity (tpc/h/ln).

Step 7: Determine Delay and Level of Service

The control delay for each lane group is calculated by using Equation 31-179 with Equation 31-180 and Equation 31-181.

Equation 31-179

$$d_i = d_{1,i} + d_{2,i}$$

with

Equation 31-180

$$d_{1,i} = PF_i \frac{0.5 C (1 - g_i/C)^2}{1 - [\min(1, X_i) g_i/C]}$$

Equation 31-181

$$d_{2,i} = 225 \left[(X_i - 1) + \sqrt{(X_i - 1)^2 + \frac{16 X_i}{c_i}} \right]$$

where

d_i = control delay for lane group i (s/veh),

$d_{1,i}$ = uniform delay for lane group i (s/veh),

$d_{2,i}$ = incremental delay for lane group i (s/veh),

PF_i = progression adjustment factor for lane group i , and

all other variables are as previously defined.

The progression adjustment factor describes the arrival distribution for the subject lane group, which may be influenced by an upstream traffic signal. Recommended progression adjustment factors are shown in Exhibit 31-38.

Exhibit 31-38

Planning-Level Analysis:
Progression Adjustment
Factor

Quality of Progression	Conditions That Describe Arrivals Associated with the Subject Lane Group	Progression Factor PF
Good progression	(a) Vehicles arrive in platoons during the green interval, OR (b) most vehicles arrive during the green interval.	0.70
Random arrivals (default)	(a) The phase serving the subject lane group is not coordinated with the upstream traffic signal, OR (b) the intersection is sufficiently distant from other signalized intersections as to be considered isolated.	1.00
Poor progression	(a) Vehicles arrive in platoons during the red interval, OR (b) most vehicles arrive during the red indication.	1.25

Lane group delay may be aggregated for each approach and for the intersection as a whole. The aggregation process is the same as that in the motorized vehicle methodology in Chapter 19 using Equation 19-28 and Equation 19-29.

Delay values may be compared with the criteria in Exhibit 19-8 to determine the LOS for a lane group, approach, or the intersection as a whole.

Protected-Permitted Left-Turn Operations

The procedure described in this subsection applies to the analysis of protected-permitted left-turn operation. The effective green time is a required input data item. If it is known or can be estimated, then the supplemental guidance in this subsection can be used with the planning-level analysis application.

Step 2: Convert Movement Volumes to Through Passenger-Car Equivalents

The guidance provided in this subsection supplements that provided in Step 2 of the planning-level analysis application. The objective is to compute an

equivalency factor for protected-permitted left-turn operation that reflects the left-turn vehicle's overall effect on operations.

A single left-turn equivalency factor is computed for both the protected and the permitted time periods. Exhibit 31-33 is used to identify the equivalency factor for protected left-turn operation during the left-turn phase. It is also used to identify the equivalency factor for permitted left-turn operation during the through phase. A single factor is calculated that weighs these two equivalency factors in proportion to the effective green times of each time period. Equation 31-182 is used to compute the single equivalency factor for left turns.

$$E_{LT} = \frac{E_{LT,pt} g_{lt,pt} + E_{LT,pm} g_{lt,pm}}{g_{lt,pt} + g_{lt,pm}}$$

Equation 31-182

where

E_{LT} = equivalency factor for left turns,

$E_{LT,pt}$ = equivalency factor for protected left-turn operation,

$E_{LT,pm}$ = equivalency factor for permitted left-turn operation,

$g_{lt,pt}$ = effective green time for the protected left-turn phase (s), and

$g_{lt,pm}$ = effective green time for permitted left-turn operation during the through phase (s).

The equivalency factor computed with Equation 31-182 is used in Equation 31-157 to compute the equivalent through movement flow rate for the left-turn lane group. The effective green time for the first time period of the protected-permitted operation includes the yellow interval that occurs between the two periods.

Step 4: Determine Critical Lane Groups

The guidance provided in this subsection supplements that provided in Step 4 of the planning-level analysis application. The objective is to compute the left-turn lane flow rate during the protected left-turn phase and then use this value to identify the critical lane groups.

The equivalent through-car flow rate in the left lane during the protected left-turn phase is estimated by distributing the lane flow rate for the left-turn lane group proportionally among the protected and permitted periods. The flow rate for the protected left-turn period is computed with Equation 31-183.

$$v_{lt,pt} = v_{lt} \frac{g_{lt,pt}}{g_{lt,pt} + g_{lt,pm}}$$

Equation 31-183

where

$v_{lt,pt}$ = lane flow rate for the left-turn lane group during the protected left-turn phase (tpc/h/ln), and

v_{lt} = lane flow rate for the left-turn lane group (tpc/h/ln).

In the process of identifying the critical lane groups (and related flow rate), only the lane flow rate during the protected left-turn phase $v_{lt,pl}$ is used for the left-turn lane group. The critical-lane flow rate is then determined by using the rules described for protected operation—with left-turn phase in Step 4b above.

The remainder of the planning-level analysis application does not change. In Step 7, the lane flow rate for the left-turn lane group v_{lt} is used to determine the delay and LOS.

WORKSHEETS

This subsection includes a series of worksheets that can be used to document an application of the planning-level analysis application. These worksheets are as follows:

- Input Worksheet (Exhibit 31-39),
- Left-Turn Treatment Worksheet (Exhibit 31-40),
- Intersection Sufficiency Worksheet (Exhibit 31-41), and
- Delay and LOS Worksheet (Exhibit 31-42).

wikitransport

Exhibit 31-39
Planning-Level Analysis: Input Worksheet

PLANNING-LEVEL ANALYSIS: INPUT WORKSHEET												
General Information						Site Information						
Analyst	_____					Intersection	_____					
Agency or Company	_____					Jurisdiction	_____					
Date Performed	_____					Analysis Year	_____					
Analysis Time Period	_____											
Intersection Geometry												
												
Volume and Signal Input												
	EB			WB			NB			SB		
	LT	TH	RT	LT	TH	RT	LT	TH	RT	LT	TH	RT
Required Data												
Volume (veh/h)												
Number of lanes												
Lane use (exclusive or shared)												
Optional Data¹												
Heavy vehicles (%)												
On-street parking presence (no, yes)												
Pedestrian activity (none, low, med., high, extreme)												
Left-turn operation and phase sequence ²												
Effective green time (s) ^{3,4}												
Progression quality (good, random, poor) ⁴												
Peak hour factor _____	Cycle length (s) _____	Base saturation flow rate (pc/h/ln) _____										
Notes												
<ol style="list-style-type: none"> 1. Optional input data (guidance is provided for estimating these data if they are not known). 2. Combinations addressed: (a) protected operation—with left-turn phase, (b) permitted operation—no left-turn phase, (c) protected operation—split phasing, (d) protected-permitted operation—with left-turn phase 3. Data required for Part I analysis if "protected-permitted operation—with left-turn phase" is present. 4. Data required for Part II analysis. 												

Exhibit 31-40
 Planning-Level Analysis: Left-Turn Treatment Worksheet

PLANNING-LEVEL ANALYSIS: LEFT-TURN TREATMENT WORKSHEET														
General Information														
Description _____														
Check # 1. Left-Turn Lane Check														
Approach	EB	WB	NB	SB										
Number of left-turn lanes														
Protected left turn (Y or N)?														
If the number of left-turn lanes on any approach exceeds 1, then it is recommended that the left turns on that the approach be protected. Those approaches with protected left turns need not be evaluated in subsequent checks.														
Check # 2. Minimum Volume Check														
Approach	EB	WB	NB	SB										
Left-turn volume														
Protected left turn (Y or N)?														
If left-turn volume on any approach exceeds 240 veh/h, then it is recommended that the left turns on that the approach be protected. Those approaches with protected left turns need not be evaluated in subsequent checks.														
Check # 3. Minimum Cross-Product Check														
Approach	EB	WB	NB	SB										
Left-turn volume, V_L (veh/h)														
Opposing mainline volume, V_o (veh/h)														
Cross product ($V_L * V_o$)														
Opposing through lanes														
Protected left turn (Y or N)?														
<table border="0" style="width: 100%; border-collapse: collapse;"> <tr> <td colspan="2" style="text-align: center;">Minimum Cross-Product Values for Recommending Left-Turn Protection</td> </tr> <tr> <td style="text-align: center;"><u>Number of Through Lanes</u></td> <td style="text-align: center;"><u>Minimum Cross Product</u></td> </tr> <tr> <td style="text-align: center;">1</td> <td style="text-align: center;">50,000</td> </tr> <tr> <td style="text-align: center;">2</td> <td style="text-align: center;">90,000</td> </tr> <tr> <td style="text-align: center;">3</td> <td style="text-align: center;">110,000</td> </tr> </table>					Minimum Cross-Product Values for Recommending Left-Turn Protection		<u>Number of Through Lanes</u>	<u>Minimum Cross Product</u>	1	50,000	2	90,000	3	110,000
Minimum Cross-Product Values for Recommending Left-Turn Protection														
<u>Number of Through Lanes</u>	<u>Minimum Cross Product</u>													
1	50,000													
2	90,000													
3	110,000													
If the cross product on any approach exceeds the above values, then it is recommended that the left turns on that approach be protected. Those approaches with protected left turns need not be evaluated in subsequent checks.														
Notes														
1. If any approach is recommended for left-turn protection but the analyst evaluates it as having permitted operation, then the planning-level analysis method may give overly optimistic results. The analyst should instead use the automobile methodology described in Chapter 19, Signalized Intersections. 2. All volumes used in this worksheet are unadjusted hourly volumes.														

PLANNING-LEVEL ANALYSIS: INTERSECTION SUFFICIENCY WORKSHEET						
General Information						
Description:						
East-West Approaches						
	Eastbound			Westbound		
	Left	Through	Right	Left	Through	Right
Movement volume, V (veh/h)						
Equivalency factor for heavy vehicles, E_{HV}						
Equivalency factor for peaking char., E_{PHF}						
Equivalency factor for right turns, E_{RT}						
Equivalency factor for left turns, E_{LT}^{-1}						
Equivalency factor for parking activity, E_p						
Equivalency factor for lane utilization, E_{LU}						
Equivalency factor for other conditions, E_{other}						
Equivalent through mvmt. flow rate (tpc/h) v_{adj} = $V E_{HV} E_{PHF} E_{LT} E_{RT} E_p E_{LU} E_{other}$						
Number of lanes, N						
Lane flow rate, v (tpc/h/ln) $v = v_{adj} / N$						
Critical lane flow rate, V_c (tpc/h/ln)						
Critical lane group (indicate with "X")						
Critical lane group flow rate, v_c (tpc/h/ln)						
Supplemental Calculations for Protected-Permitted Operation						
Equivalency factor for prot. left turn, $E_{LT,pt}$						
Equivalency factor for perm. left turn, $E_{LT,pm}$						
Effective green for prot. left turn, $g_{t,pt}$ (s)						
Effective green for perm. left turn, $g_{t,pm}$ (s)						
Equivalency factor for left turns, E_{LT} $E_{LT} = (E_{LT,pt} g_{t,pt} + E_{LT,pm} g_{t,pm}) / (g_{t,pt} + g_{t,pm})$						
North-South Approaches						
	Northbound			Southbound		
	Left	Through	Right	Left	Through	Right
Movement volume, V (veh/h)						
Equivalency factor for heavy vehicles, E_{HV}						
Equivalency factor for peaking char., E_{PHF}						
Equivalency factor for right turns, E_{RT}						
Equivalency factor for left turns, E_{LT}^{-1}						
Equivalency factor for parking activity, E_p						
Equivalency factor for lane utilization, E_{LU}						
Equivalency factor for other conditions, E_{other}						
Equivalent through mvmt. flow rate (tpc/h) v_{adj} = $V E_{HV} E_{PHF} E_{LT} E_{RT} E_p E_{LU} E_{other}$						
Number of lanes, N						
Lane flow rate, v (tpc/h/ln) $v = v_{adj} / N$						
Critical lane flow rate, V_c (tpc/h/ln)						
Critical lane group (indicate with "X")						
Critical lane group flow rate, v_c (tpc/h/ln)						
Supplemental Calculations for Protected-Permitted Operation						
Equivalency factor for prot. left turn, $E_{LT,pt}$						
Equivalency factor for perm. left turn, $E_{LT,pm}$						
Effective green for prot. left turn, $g_{t,pt}$ (s)						
Effective green for perm. left turn, $g_{t,pm}$ (s)						
Equivalency factor for left turns, E_{LT} $E_{LT} = (E_{LT,pt} g_{t,pt} + E_{LT,pm} g_{t,pm}) / (g_{t,pt} + g_{t,pm})$						
Intersection Sufficiency Assessment						
Number of critical phases, n_{cp}		Intersection capacity, c_I (tpc/h/ln) $c_I = s_o [C - (n_{cp} 4.0)] / C$				
Sum of critical lane flow rates, V_c (tpc/h/ln)		Critical intersection vol.-to-capacity ratio, X_c $X_c = V_c / c_I$				
Intersection status (relationship to capacity)		Under ___ Near ___ Over ___				
Note						
1. If the approach has protected-permitted operation, use the supplemental calculations section to compute E_{LT} .						

Exhibit 31-41
Planning Level Analysis:
Intersection Sufficiency
Worksheet

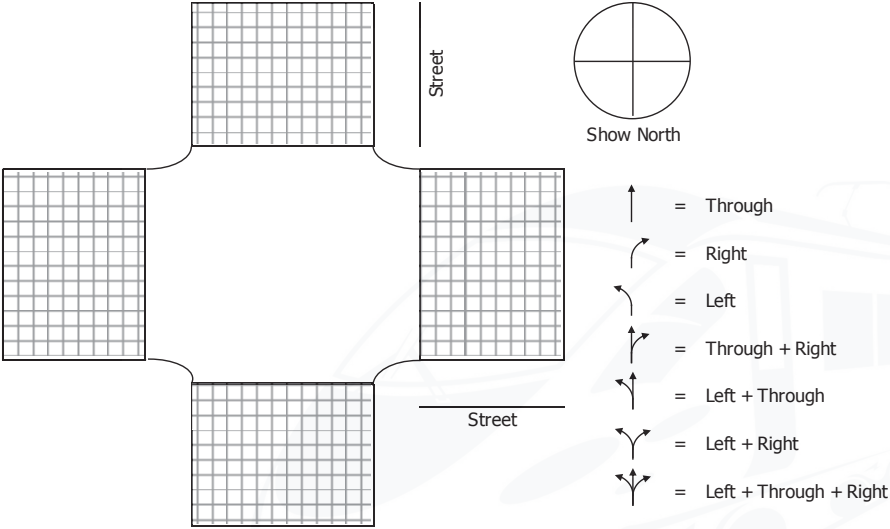
Exhibit 31-42
 Planning-Level Analysis: Delay
 and LOS Worksheet

PLANNING-LEVEL ANALYSIS: DELAY AND LOS WORKSHEET						
General Information						
Description _____						
Green Time Calculation						
Total effective green time, g_{tot} (s) $g_{tot} = C - (n_{cp} \cdot 4.0)$						
East-West Approaches			Eastbound		Westbound	
			Left	Through	Right	Left
Critical lane group flow rate, v_c (tpc/h/ln) ¹						
Effective green time for critical lane group, g_c (s) $g_c = g_{tot} \cdot v_c / V_c$						
			Phase No. 1		Phase No. 2	
Effective green time, g (s)						
North-South Approaches			Northbound		Southbound	
			Left	Through	Right	Left
Critical lane group flow rate, v_c (tpc/h/ln) ¹						
Effective green time for critical lane group, g_c (s) $g_c = g_{tot} \cdot v_c / V_c$						
			Phase No. 1		Phase No. 2	
Effective green time, g (s)						
Control Delay and LOS						
	EB	WB	NB	SB		
Lane group						
Effective green time, g (s)						
Green-to-cycle-length ratio, g/C						
Number of lanes, N^1						
Lane group capacity, c (veh/h) $c = 1900 N g/C$						
Lane flow rate, v (tpc/h/ln) ¹						
Volume-to-capacity ratio, X $X = (N v)/c$						
Progression adjustment factor, PF						
Uniform delay, d_1 (s/veh)						
Incremental delay, d_2 (s/veh)						
Control delay, $d = d_1 + d_2$ (s/veh)						
Approach delay, d_A (s/veh) $d_A = \Sigma(d N v) / \Sigma(N v)$						
Approach flow rate, V_A (veh/h)						
Intersection delay, d_I (s/veh) $d_I = \Sigma(d_A V_A) / \Sigma V_A$			Intersection LOS (Exhibit 19-8)			
Intersection capacity, c_{sum} (tpc/h/ln) $c_{sum} = 1900 (\Sigma g_c) / C$		Critical intersection vol.-to-capacity ratio, X_c $X_c = V_c / c_{sum}$				
Notes						
1. Value obtained from the Intersection Sufficiency Worksheet.						

6. FIELD MEASUREMENT TECHNIQUES

This section describes two techniques for estimating key traffic characteristics by using field data. The first subsection describes a technique for estimating control delay. The second subsection describes a technique for estimating saturation flow rate.

FIELD MEASUREMENT OF INTERSECTION CONTROL DELAY

Delay can be measured at existing intersections as an alternative to estimating delay by using the motorized vehicle methodology in Chapter 19, Signalized Intersections. Various techniques can be used for measuring delay, including a test-car survey, vehicle path tracing, input–output analysis, and queue counting. The first three techniques tend to require more time to implement than the last technique, but they provide more accurate delay estimates. They are often limited to sampling when implemented manually. They may be more appropriate when oversaturated conditions are present. The first two techniques can be used to estimate delay on either a movement basis or a lane group basis. The last two techniques are more amenable to delay measurement on a lane group basis.

The queue-count technique is recommended for control delay measurement. It is based on direct observation of vehicle-in-queue counts for a subject lane group. It normally requires two field personnel for each lane group surveyed. Also needed are (a) a multifunction digital watch that includes a countdown-repeat timer, with the countdown interval in seconds; and (b) a volume-count board with at least two tally counters. Alternatively, a laptop computer can be programmed to emit audio count markers at user-selected intervals, take volume counts, and execute real-time delay computations.

The queue-count technique is applicable to all undersaturated lane groups. Significant queue buildup can make the technique impractical for oversaturated lane groups or lane groups with limited storage length. If queues are lengthy, then the technique should be modified by subdividing the lane group into manageable segments (or zones) and assigning an observer to each zone. Each observer then counts queued vehicles in his or her assigned zone.

If queues are lengthy or the volume-to-capacity ratio is near 1.0, then care must be taken to continue the vehicle-in-queue count past the end of the arrival count period, as detailed in subsequent paragraphs. This extended counting period is required for consistency with the analytic delay equation used in the chapter text.

The queue-count technique does not directly measure delay during deceleration and during a portion of acceleration. These delay elements are very difficult to measure without sophisticated tracking equipment. Nevertheless, this technique has been shown to yield a reasonable estimate of control delay by application of appropriate adjustment factors (8, 9). One adjustment factor accounts for sampling errors that may occur. Another factor accounts for

unmeasured acceleration–deceleration delay. This adjustment factor is a function of the number of vehicles in queue each cycle and the approach speed.

Approach Speed

Exhibit 31-43 shows a worksheet that can be used for recording observations and computing control delay for the subject lane group. Before starting the survey, observers need to estimate the average approach speed during the study period. Approach speed is the speed at which vehicles would pass unimpeded through the intersection if the signal were green for an extended period and volume was light. This speed may be obtained by driving through the intersection a few times when the signal is green and there is no queue. The approach speed is recorded at an upstream location that is least affected by the operation of the subject signalized intersection as well as the operation of any other signalized intersection.

Survey Period

The duration of the survey period must be clearly defined in advance so the last arriving vehicle or vehicles that stop in the period can be identified and counted until they exit the intersection. It is logical to define the survey period on the basis of the same considerations used to define an evaluation analysis period (as described in Section 3 of Chapter 19). A typical survey period is 15 min.

Count Interval

The survey technique is based on recording a vehicle-in-queue count at specific points in time. A count interval in the range of 10 to 20 s has been found to provide a good balance between delay estimate precision and observer capability. The actual count interval selected from this range is based on consideration of survey period duration and the type of control used at the intersection.

The count interval *should* be an integral divisor of the survey period duration. This characteristic ensures that a complete count of events is taken for the full survey period. It also allows easier coordination of observer tasks during the field study. For example, if the study period is 15 min, the count interval can be 10, 12, 15, 18, or 20 s.

If the intersection has pretimed or coordinated-actuated control, the count interval *should not* be an integral divisor of the cycle length. This characteristic eliminates potential survey bias due to queue buildup in a cyclical pattern. For example, if the cycle length is 120 s, the count interval can be 11, 13, 14, 16, 17, 18, or 19 s.

If the intersection has actuated control, the count interval may be chosen as the most convenient value for conducting the field survey with consideration of survey period duration.

stopped vehicle and is itself about to stop. This definition is used because of the difficulty of keeping track of the moment when a vehicle comes to a stop.

2. At the start of each count interval, Observer 1 records the number of vehicles in queue in all lanes of the subject lane group. The countdown-repeat timer on a digital watch can be used to signal the count time. This count includes vehicles that arrive when the signal is actually green but stop because queued vehicles ahead have not yet started moving. All vehicles that join a queue are included in the vehicle-in-queue count until they “exit” the intersection. A through vehicle exits the intersection when its rear axle crosses the stop line. A turning vehicle exits the intersection the instant it clears the opposing through traffic (or pedestrians to which it must yield) and begins accelerating back to the approach speed. The vehicle-in-queue count often includes some vehicles that have regained speed but have not yet exited the intersection.
3. Observer 1 records the vehicle-in-queue count in the appropriate count-interval box on the worksheet. Ten boxes are provided for each “count cycle” (note that a count cycle is not the same as a signal cycle). Any number of boxes can be used to define the count cycle; however, as many as possible should be used to ensure best use of worksheet space. The clock time at the start of the count cycle is recorded in the first (far-left) column. The count cycle number is recorded in the second column of the sheet.
4. At the end of the survey period, Observer 1 continues taking vehicle-in-queue counts for all vehicles that arrived during the survey period until all of them have exited the intersection. This step requires the observer to make a mental note of the last stopping vehicle that arrived during the survey period in each lane of the lane group and continue the vehicle-in-queue counts until the last stopping vehicle or vehicles, plus all vehicles in front of the last stopping vehicle(s), exit the intersection. Stopping vehicles that arrive after the end of the survey period are not included in the final vehicle-in-queue counts.

Observer 2 Tasks

5. Observer 2 maintains three counts during the survey period. The first is a count of the vehicles that arrive during the survey period. The second is a count of the vehicles that arrive during the survey period and that stop one or more times. A vehicle stopping multiple times is counted only once as a stopping vehicle. The third count is the count of signal cycles, as measured by the number of times the red indication is presented for the subject lane group. For lane groups with a turn movement and protected or protected-permitted operation, the protected red indication is used for this purpose. If the survey period does not start or end at the same time as the presentation of a red indication, then the number of count intervals that occur in the interim can be used to estimate the fraction of the cycle that occurred at the start or end of the survey period.
6. Observer 2 enters all counts in the appropriate boxes on the worksheet.

Data Reduction Tasks

7. Sum each column of vehicle-in-queue counts, then sum the column totals for the entire survey period.
8. A vehicle recorded as part of a vehicle-in-queue count is assumed to be in queue, on average, for the time interval between counts. On this basis, the average time in queue per vehicle arriving during the survey period is estimated with Equation 31-184.

$$d_{vq} = 0.9 \left(I_s \frac{\sum V_{iq}}{V_{tot}} \right)$$

Equation 31-184

where

d_{vq} = time in queue per vehicle (s/veh),

I_s = interval between vehicle-in-queue counts (s),

$\sum V_{iq}$ = sum of vehicle-in-queue counts (veh), and

V_{tot} = total number of vehicles arriving during the survey period (veh).

The 0.9 adjustment factor in Equation 31-184 accounts for the errors that may occur when the queue-count technique is used to estimate delay. Research has shown the adjustment factor value is fairly constant for a variety of conditions (8).

9. Compute the fraction of vehicles stopping and the average number of vehicles stopping per lane in each signal cycle, as indicated on the worksheet.
10. Use Exhibit 31-44 to look up the correction factor appropriate to the lane group approach speed and the average number of vehicles stopping per lane in each cycle. This factor adjusts for deceleration and acceleration delay, which cannot be measured directly with manual techniques (9).

Approach Speed (mi/h)	Acceleration–Deceleration Correction Factor CF (s/veh) As a Function of the Average Number of Vehicles Stopping		
	≤ 7 veh/ln/cycle	8–19 veh/ln/cycle	20–30 veh/ln/cycle ^a
≤ 37	+5	+2	-1
>37–45	+7	+4	+2
>45	+9	+7	+5

Exhibit 31-44
Acceleration–Deceleration Correction Factor

Note: ^a Vehicle-in-queue counts in excess of about 30 veh/ln/cycle are typically unreliable.

11. Multiply the correction factor by the fraction of vehicles stopping. Add this product to the time-in-queue value from Task 2 to obtain the estimate of control delay for the subject lane group.

Example Application

Exhibit 31-45 presents sample data for a lane group during a 15-min survey period. The intersection has a 115-s cycle. A 15-s count interval is selected because 15 is not an integral divisor of the cycle length, but it is an integral divisor of the survey period.

Concepts

The saturation flow rate represents the maximum rate of flow in a traffic lane, as measured at the stop line during the green indication. It is usually achieved after 10 to 14 s of green, which corresponds to the front axle of the fourth to sixth queued passenger car crossing the stop line.

The base saturation flow rate represents the saturation flow rate for a traffic lane that is 12 ft wide and has no heavy vehicles, a flat grade, no parking, no buses that stop at the intersection, even lane utilization, and no turning vehicles. It is usually stable over a period of time in a given area and normally exhibits a relatively narrow distribution among intersections in that area.

The prevailing saturation flow rate is the rate measured in the field for a specific lane group at a specific intersection. It may vary significantly among intersections with similar lane groups because of differences in lane width, traffic composition (i.e., percentage of heavy vehicles), grade, parking, bus stops, lane use, and turning vehicle operation. If the intersections are located in different areas, then the prevailing saturation flow rate may also vary because of areawide differences in the base saturation flow rate.

The adjusted saturation flow rate is the rate computed by the procedure described in Chapter 19. It represents an estimate of the prevailing saturation flow rate. It can vary among intersections for the same reasons as stated above for the prevailing saturation flow rate. Any potential bias in the estimate is minimized by local calibration of the base saturation flow rate.

The prevailing saturation flow rate and the adjusted saturation flow rate are both expressed in units of vehicles. As a result, their value reflects the traffic composition in the subject traffic lane. In contrast, the base saturation flow rate is expressed in units of passenger cars and does not reflect traffic composition.

Measurement Technique

This subsection describes the technique for measuring the prevailing saturation flow rate for a given traffic lane. In general, vehicles are recorded when their front axles cross the stop line. The measurement period starts at the beginning of the green interval or when the front axle of the first vehicle in the queue passes the stop line. Saturation flow rate is calculated only from the data recorded after the fourth vehicle in the queue passes the stop line.

The vehicle's front axle, the stop line, and the time the fourth queued vehicle crosses the stop line represent three key reference points for saturation flow measurement. These three reference points must be maintained to ensure consistency with the procedure described in Chapter 19 and to facilitate comparability of results with other studies. The use of other reference points on the vehicle, on the road, or in time may yield different saturation flow rates.

If the stop line is not visible or if vehicles consistently stop beyond the stop line, then an alternative reference line must be established. This reference line should be established just beyond the typical stopping position of the first queued vehicle. Vehicles should consistently stop behind this line. Observation of several cycles before the start of the study should be sufficient to identify this substitute reference line.

The following paragraphs describe the tasks associated with a single-lane saturation flow survey. A two-person field crew is recommended. However, one person with a tape recorder, push-button event recorder, or a notebook computer with appropriate software will suffice. The field notes and tasks identified in the following paragraphs must be adjusted according to the type of equipment used. A sample field worksheet for recording observations is included as Exhibit 31-47.

Exhibit 31-47
Saturation Flow Rate Field Study Worksheet

FIELD SATURATION FLOW RATE STUDY WORKSHEET																		
General Information									Site Information									
Analyst _____ Agency or Company _____ Date Performed _____ Analysis Time Period _____									Intersection _____ Area Type <input type="checkbox"/> CBD <input type="checkbox"/> Other Jurisdiction _____ Analysis Year _____									
Lane Movement Input																		
Input Field Measurement																		
Veh. in queue	Cycle 1			Cycle 2			Cycle 3			Cycle 4			Cycle 5			Cycle 6		
	Time	HV	T	Time	HV	T	Time	HV	T	Time	HV	T	Time	HV	T	Time	HV	T
1																		
2																		
3																		
4																		
5																		
6																		
7																		
8																		
9																		
10																		
11																		
12																		
13																		
14																		
15																		
16																		
17																		
18																		
19																		
20																		
End of saturation																		
End of green																		
No. veh. > 20																		
No. veh. on yellow																		
Glossary and Notes																		
HV = Heavy vehicles (vehicles with more than 4 tires on pavement) T = Turning vehicles (L = Left, R = Right) Pedestrians and buses that block vehicles should be noted with the time that they block traffic, for example, P12 = Pedestrians blocked traffic for 12 s B15 = Bus blocked for 15 s																		

General Tasks

Measure and record the area type as well as the width and grade of the lane being studied. Enter these data in the lane movement input section of the field worksheet.

Select an observation point where the roadway reference line (e.g., stop line) for the surveyed lane and the corresponding signal heads are clearly visible. When a vehicle crosses this line unimpeded, it has entered the intersection conflict space for the purpose of saturation flow measurement. Left- or right-turning vehicles yielding to opposing through traffic or yielding to pedestrians are not recorded until they proceed through the opposing traffic or pedestrians.

Recorder Tasks

During the measurement period, note the last vehicle in the stopped queue when the signal turns green. Describe the last vehicle to the timer. Note on the worksheet which vehicles are heavy vehicles and which vehicles turn left or right. Record the time called out by the timer.

Timer Tasks

Start the stopwatch at the beginning of the green indication and notify the recorder. Count aloud each vehicle in the queue as its front axle crosses the stop line and note the time of crossing. Call out the time of the fourth, 10th, and last vehicle in the stopped queue as its front axle crosses the stop line.

If queued vehicles are still entering the intersection at the end of the green interval, call out “saturation through the end of green—last vehicle was number XX.” Note any unusual events that may have influenced the saturation flow rate, such as buses, stalled vehicles, and unloading trucks.

The period of saturation flow begins when the front axle of the fourth vehicle in the queue crosses the roadway reference line (e.g., stop line) and ends when the front axle of the last queued vehicle crosses this line. The last queued vehicle may be a vehicle that joined the queue during the green indication.

Data Reduction

Measurements are taken cycle by cycle. To reduce the data for each cycle, the time recorded for the fourth vehicle is subtracted from the time recorded for the last vehicle in the queue. This value represents the sum of the headways for the fifth through n th vehicle, where n is the number of the last vehicle surveyed (which may not be the last vehicle in the queue). This sum is divided by the number of headways after the fourth vehicle [i.e., divided by $(n - 4)$] to obtain the average headway per vehicle under saturation flow. The saturation flow rate is 3,600 divided by this average headway.

For example, if the time for the fourth vehicle was observed as 10.2 s and the time for the 14th and last vehicle surveyed was 36.5 s, the average saturation headway per vehicle is as follows:

$$\frac{(36.5 - 10.2)}{(14 - 4)} = \frac{26.3}{10} = 2.63 \text{ s/veh}$$

The prevailing saturation flow rate in that cycle is as follows:

$$\frac{3,600}{2.63} = 1,369 \text{ veh/h/ln}$$

To obtain a statistically significant value, a minimum of 15 signal cycles (each with more than eight vehicles in the initial queue) is typically required. The average of the saturation headway per vehicle values from the individual cycles is divided into 3,600 to obtain the prevailing saturation flow rate for the surveyed lane. The percentage of heavy vehicles and turning vehicles in the sample should be determined and noted for reference.

Calibration Technique

This subsection describes a technique for quantifying the base saturation flow rate at a local level. It consists of three tasks. The first task entails measuring the prevailing saturation flow rate at representative locations in the local area. The second task requires the calculation of an adjusted saturation flow rate for the same locations where a prevailing saturation flow rate was measured. The third task combines the information to compute the local base saturation flow rate.

This technique will require some resource investment by the agency. However, it should need to be completed only once every few years. In fact, it should be repeated only when there is evidence of a change in local driver behavior. The benefit of this calibration activity will be realized by the agency in terms of more accurate estimates of motorized vehicle performance, which should translate into more effective decisions related to infrastructure investment and system management.

Task 1. Measure Prevailing Saturation Flow Rate

This task requires measuring the prevailing saturation flow rate of one or more lane groups at each of several representative intersections in the local area. The minimum number of lane groups needed in the data set is difficult to judge for all situations; however, it should reflect a statistically valid sample. The data set should also provide a reasonable geographic and physical representation of the population of signalized intersections in the local area.

The lane groups for which the prevailing saturation flow rate is measured should include a representative mix of left-turn, through, and right-turn lane groups. It should not include left-turn lane groups that operate in the permitted or the protected-permitted mode or right-turn lane groups that have protected-permitted operation. These lane groups are excluded because of the complex nature of permitted and protected-permitted operation. The saturation flow rate for these lane groups tends to have a large amount of random variation that makes it more difficult to quantify the local base saturation flow rate with an acceptable level of precision.

Once the set of lane groups is identified, the technique described in the previous subsection is used to measure the prevailing saturation flow rate at each location.

Task 2. Compute Adjusted Saturation Flow Rate

For this task, the saturation flow rate calculation procedure in Chapter 19 is used to compute the adjusted saturation flow rate for each lane group in the data set. If a lane group is at an intersection with actuated control for one or more phases, the motorized vehicle methodology (as opposed to just the saturation flow rate procedure) will be needed to compute the adjusted saturation flow rate accurately. Regardless, the base saturation flow rate used with the procedure (or methodology) for this task must be 1,900 pc/h/ln.

Task 3. Compute Local Base Saturation Flow Rate

The local base saturation flow rate is computed with Equation 31-185.

Equation 31-185

$$s_{o,local} = 1,900 \frac{\sum_{i=1}^m s_{prevailing,i}}{\sum_{i=1}^m s_i}$$

where

$s_{o,local}$ = local base saturation flow rate (pc/h/ln),

$s_{prevailing,i}$ = prevailing saturation flow rate for lane group i (veh/h/ln),

s_i = (adjusted) saturation flow rate for lane group i (veh/h/ln), and

m = number of lane groups.

Once the local base saturation flow rate $s_{o,local}$ is quantified by this technique, it is substituted thereafter for s_o in any equation in an HCM chapter that refers to this variable.

wikitransport

7. COMPUTATIONAL ENGINE DOCUMENTATION

This section uses a series of flowcharts and linkage lists to document the logic flow for the computational engine.

FLOWCHARTS

The methodology flowchart is shown in Exhibit 31-48. The methodology is shown to consist of four main modules:

- Setup module,
- Signalized intersection module,
- Initial queue delay module, and
- Performance measures module.

This subsection provides a separate flowchart for each of these modules.

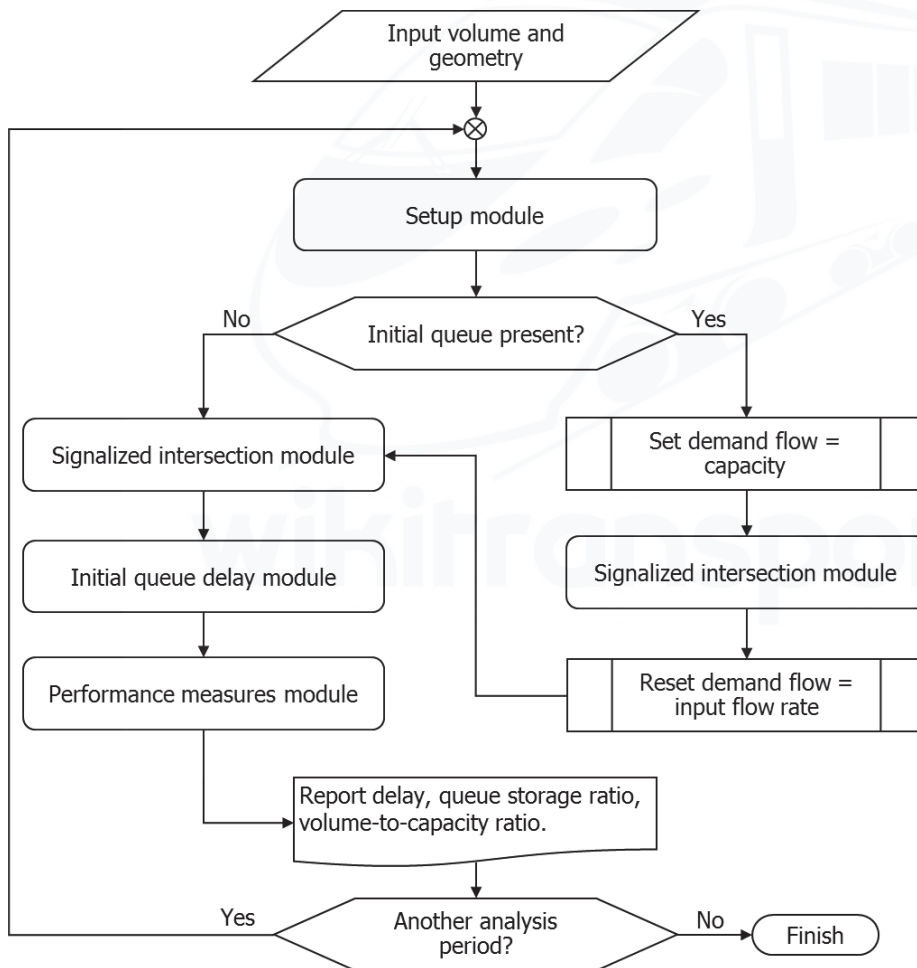
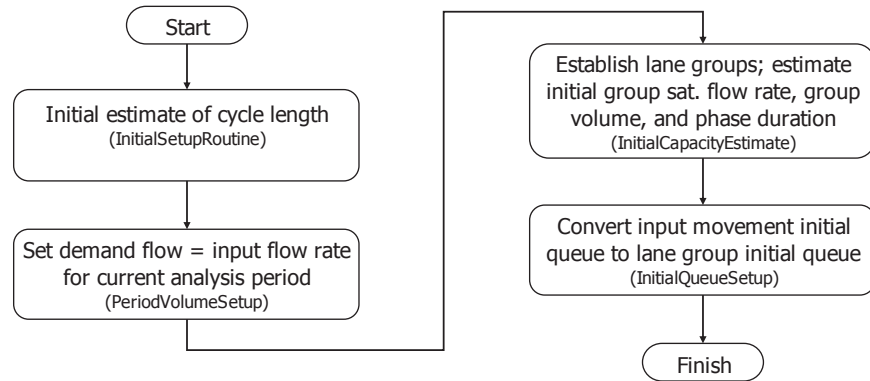

Exhibit 31-48
Methodology Flowchart

The setup module is shown in Exhibit 31-49. It consists of four main routines, as shown in the large rectangles of the exhibit. The main function of each routine, as well as the name given to it in the computational engine, is shown in the exhibit. These routines are described further in the next subsection.

Exhibit 31-49
Setup Module



The signalized intersection module is shown in Exhibit 31-50. It consists of nine main routines followed by a tenth and final computation routine performed after the final phase duration equals the initial phase duration. The main function of each routine, as well as the name given to it in the computational engine, is shown in the exhibit. These routines are described further in the next subsection.

Exhibit 31-50
Signalized Intersection Module

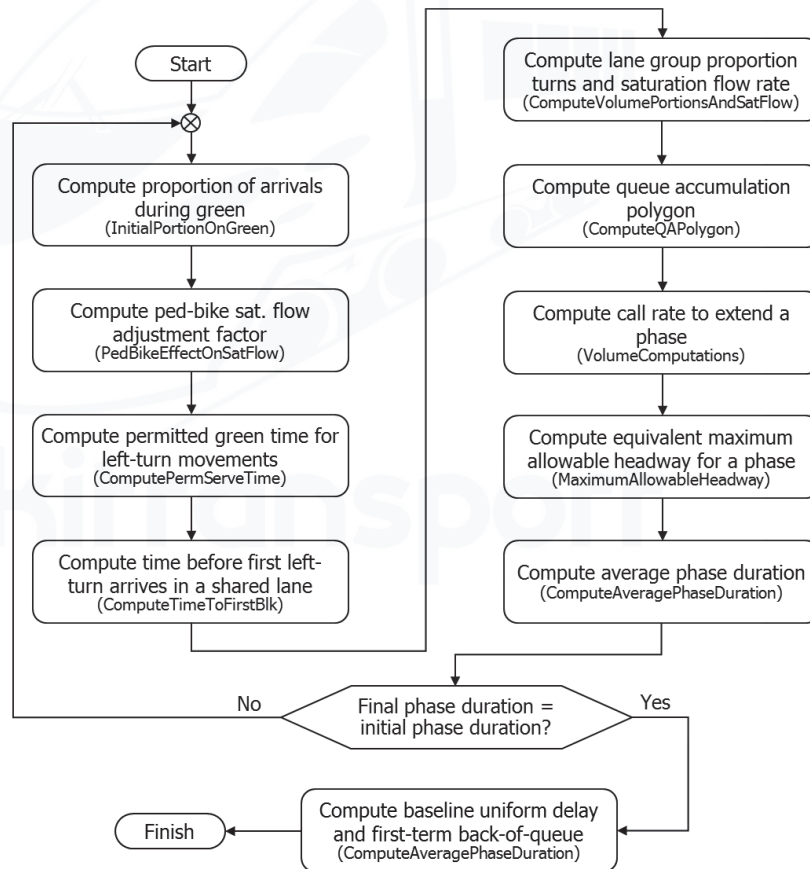

The initial queue delay module is shown in Exhibit 31-51. It consists of four main routines. The main function of each routine is shown in the exhibit.

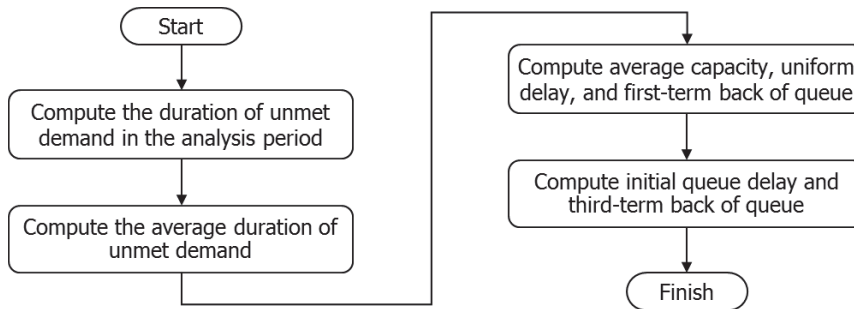

Exhibit 31-51
Initial Queue Delay Module

The performance measures module is shown in Exhibit 31-52. It consists of four main routines. The main function of each routine is shown in the exhibit. Two of the routines are complicated enough to justify their development as separate entities in the computational engine. The name given to each of these two routines is also shown in the exhibit, and they are described further in the next subsection.

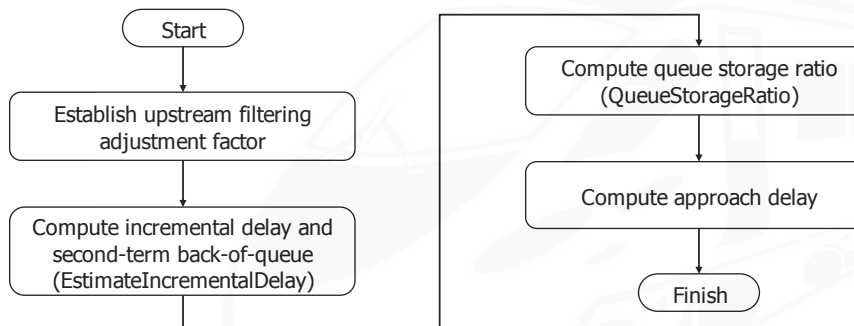

Exhibit 31-52
Performance Measures Module

LINKAGE LISTS

This subsection uses linkage lists to describe the main routines that compose the computational engine. Each list is provided in a table (an exhibit) that identifies the routine and the various subroutines to which it refers. Conditions for which the subroutines are used are also provided.

The lists are organized by module, as described in the previous subsection. Four tables are provided to address the following three modules:

- Setup module (one table),
- Signalized intersection module (two tables), and
- Performance measures module (one table).

The initial queue delay module does not have a linkage list because it does not call any specific routines.

The linkage list for the setup module is provided in Exhibit 31-53. The main routines are listed in the far-left column of the exhibit and are identified in Exhibit 31-49.

Exhibit 31-53
Setup Module Routines

Routine	Subroutine	Conditions for Use
InitialSetupRoutine	Compute change period ($Y + R_c$).	None
	Compute initial estimate of cycle length C .	None
PeriodVolumeSetup	a. Compute period volume before initial queue analysis, and b. Restore period volume if initial queue analysis conducted.	Used for multiple-period analysis
	a. Save input volume as it will be overwritten if initial queue is present, and b. Restore input volume if initial queue analysis conducted.	Used for single-period analysis
InitialCapacityEstimate	getPermissiveLeftServiceTime (computes g_u , the duration of the permitted period that is not blocked by an opposing queue)	Used if subject phase serves a left-turn movement with a. permitted mode or b. protected-permitted mode
	getPermissiveLeftEffGreen (computes g_p , the duration of the permitted green for permitted left-turn movements)	Used if subject phase serves a left-turn movement with a. permitted mode or b. protected-permitted mode
	Define lane groups for each approach.	None
	Establish initial estimate of lane group volume, saturation flow rate, and number of lanes capacity.	None
	Establish initial estimate of proportion of turns in a shared-lane lane group.	Used for shared-lane lane groups
	PermittedSatFlow (computes permitted left-turn saturation flow rate s_p)	Used if lane group serves a left-turn movement with protected-permitted mode
	getParkBusSatFlowAdj (computes combined parking and bus blockage saturation flow adjustment factors)	Used if lane group is adjacent to on-street parking or a local bus stop
Establish initial estimate of queue service time g_s .	None	
InitialQueueSetup	Distribute input movement initial queue to corresponding lane groups.	Used for first analysis period
	Assign residual queue from last period to initial queue of current period, and distribute initial queue among affected lane groups.	Used for second and subsequent analysis periods

The linkage list for the signalized intersection module is provided in Exhibit 31-54. The main routines are listed in the far-left column of the exhibit and are identified in Exhibit 31-50. The ComputeQAPolygon routine is complex enough to justify the presentation of its subroutines in a separate linkage list. This supplemental list is provided in Exhibit 31-55.

Routine	Subroutine	Conditions for Use
InitialPortionOnGreen	Compute portion arriving during green P .	None
PedBikeEffectOnSatFlow	PedBikeEffectOnLefts	Used if subject phase serves a left-turn movement with a. permitted mode or b. protected-permitted mode
	PedBikeEffectOnRights	Used if subject phase serves a right-turn movement
	PedBikeEffectOnLeftsUnopposed	Used if subject phase serves a left-turn movement with split phasing
ComputePermServeTime	getPermissiveLeftServiceTime (computes g_u , the duration of the permitted period that is not blocked by an opposing queue)	Used if subject phase serves a left-turn movement with a. permitted mode or b. protected-permitted mode
	getPermissiveLeftEffGreen (computes g_p , the duration of the permitted green for permitted left-turn movements)	Used if subject phase serves a left-turn movement with a. permitted mode or b. protected-permitted mode
ComputeTimeToFirstBlk	getTimetoFirstBlk (computes g_r , the time before the first left-turning vehicle arrives and blocks the shared lane)	Used if subject phase serves a left-turn movement in a shared lane with a. permitted mode or b. protected-permitted mode
ComputeVolumePortions-AndSatFlow	PermittedSatFlow (computes permitted left-turn saturation flow rate s_p)	Used if lane group serves a left-turn movement with protected-permitted mode
	PortionTurnsInSharedTRLane (computes proportion of right-turning vehicles in shared lane P_R)	Used if approach has exclusive left-turn lane and subject lane group is a shared lane serving through and right-turning vehicles
	SatFlowforPermExclLefts	Used if lane group serves a left-turn movement with a permitted mode in an exclusive lane
	PortionTurnsInSharedLTRLane (computes proportion of right-turning vehicles in shared lane P_R and proportion of left-turning vehicles in shared lane P_L)	Used if approach has a shared lane serving left-turn and through vehicles
ComputeQAPolygon	QAP_ProtPermExclLane	Used if lane group serves a left-turn movement in an exclusive lane with the protected-permitted mode
	QAP_ProtMvmtExclLane	Used if lane group's movement has an exclusive lane and is served with protected mode
	QAP_ProtSharedLane	Used if lane group has a. a shared lane with through and right-turning movements b. a shared lane with through and left-turning movements served with split phasing
	QAP_PermLeftExclLane	Used if lane group serves a left-turn movement in an exclusive lane with the permitted mode
	QAP_PermSharedLane	Used if lane group serves a left-turn movement in a shared lane with the permitted mode

Exhibit 31-54
Signalized Intersection
Module: Main Routines

Exhibit 31-54 (continued)
 Signalized Intersection
 Module: Main Routines

Routine	Subroutine	Conditions for Use
VolumeComputations	Determine call rate to extend green λ .	None
	Determine call rate to activate a phase q_v, q_p	None
MaximumAllowable-Headway	Compute maximum allowable headway for each lane group MAH .	Calculations vary depending on lane group movements, lane assignment, phase sequence, and left-turn operational mode.
	Compute equivalent maximum allowable headway for each phase and timer MAH^* .	None
ComputeAverage-PhaseDuration	Compute probability of green extension p .	Computed for all phases except for the timer that serves the protected left-turn movement in a shared lane
	Compute maximum queue service time for all lane groups served during the phase.	None
	Compute probability of phase termination by extension to maximum limit (i.e., max-out).	None
	Compute green extension time g_e .	None
	Compute probability of a phase call p_c .	None
	Compute unbalanced green duration G_u .	None
	Compute average phase duration D_p .	None



Routine	Subroutine	Conditions for Use
QAP_ProtPermExclLane	ADP_ProtPermExcl (compute baseline first-term back-of-queue estimate $Q_{1,b}$)	Used for lane groups with left-turn movements in exclusive lane and served by protected-permitted mode
	getUniformDelay (compute baseline uniform delay $d_{1,b}$)	None
	Compute queue service time g_s .	None
	Compute lane group available capacity.	None
	Compute movement capacity.	None
QAP_ProtMvmtExclLane	ADP_ProtMvmt (compute baseline first-term back-of-queue estimate $Q_{1,b}$)	Used for lane groups with one service period
	getUniformDelay (compute baseline uniform delay $d_{1,b}$)	None
	Compute queue service time g_s .	None
	Compute lane group available capacity.	None
	Compute movement capacity.	None
QAP_ProtSharedLane	ADP_ProtMvmt (compute baseline first-term back-of-queue estimate $Q_{1,b}$)	Used for lane groups with one service period
	getUniformDelay (compute baseline uniform delay $d_{1,b}$)	None
	Compute queue service time g_s .	None
	Compute lane group available capacity.	None
	Compute movement capacity.	None
QAP_PermLeftExclLane	ADP_PermLeftExclLane (compute baseline first-term back-of-queue estimate $Q_{1,b}$)	Used for lane groups with left-turn movements in exclusive lane and served by permitted mode
	getUniformDelay (compute baseline uniform delay $d_{1,b}$)	None
	Compute queue service time g_s .	None
	Compute lane group available capacity.	None
	Compute movement capacity.	None
QAP_PermSharedLane	ADP_PermSharedMvmt (compute baseline first-term back-of-queue estimate $Q_{1,b}$)	Used for shared-lane lane groups with a permitted left-turn movement
	ADP_ProtMvmt (compute baseline first-term back-of-queue estimate $Q_{1,b}$)	Used for lane groups with one service period
	ADP_ProtPermShared (compute baseline first-term back-of-queue estimate $Q_{1,b}$)	Used for lane groups with left-turn movements in shared-lane lane group and served by protected-permitted mode
	getUniformDelay (compute baseline uniform delay $d_{1,b}$)	None
	Compute queue service time g_s .	None
	Compute lane group available capacity.	None
	Compute movement capacity.	None

Exhibit 31-55
Signalized Intersection
Module: ComputeQAPolygon
Routines

The linkage list for the performance measures module is provided in Exhibit 31-56. The main routines are listed in the far-left column and are identified in Exhibit 31-52.

Exhibit 31-56
Performance Measures
Module Routines

Routine	Subroutine	Conditions for Use
EstimateIncrementalDelay	Compute incremental delay d_2 and second-term back-of-queue estimate Q_2 .	None
QueueStorageRatio	Compute queue storage ratio L_Q .	None



8. USE OF ALTERNATIVE TOOLS

This section illustrates the use of alternative evaluation tools to evaluate the operation of a signalized intersection. The intersection described in Example Problem 1 of Section 9 is used for this purpose. There are no limitations in this example that would suggest the need for alternative tools. However, it is possible to introduce situations, such as short left-turn bays, for which an alternative tool might provide a more realistic assessment of intersection operation.

The basic layout of the example intersection is shown in the second exhibit of Example Problem 1 of Section 9. The left-turn movements on the north-south street operate under protected-permitted control and lead the opposing through movements (i.e., a lead-lead phase sequence). The left-turn movements on the east-west street operate as permitted. To simplify the discussion, the pedestrian and parking activity is removed. A pretimed signal operation is used.

EFFECT OF STORAGE BAY OVERFLOW

The effect of left-turn storage bay overflow is described in this subsection as a means of illustrating the use of alternative tools. The motorized vehicle methodology in Chapter 19 can be used to compute a queue storage ratio that compares the back-of-queue estimate with the available storage length. This ratio is used to identify bays that have inadequate storage. Overflow from a storage bay can be expected to reduce approach capacity and increase the approach delay. However, these effects of bay overflow are not addressed by the motorized vehicle methodology.

Effect of Overflow on Approach Throughput and Delay

A simulation software product was selected as the alternative tool for this analysis. The intersection was simulated for a range of storage bay lengths from 0 to 250 ft. All other input data remained the same. The results presented here represent the average of 30 simulation runs for each case.

The effect of bay overflow was assessed by examining the relationship between bay length, approach throughput, and approach delay. Exhibit 31-57 shows this effect. The throughput on each approach is equal to the demand volume when storage is adequate but drops off when the bay length is decreased.

A delay comparison is also presented in Exhibit 31-57. The delay on each approach increases as bay length is reduced. The highest delay is associated with a zero-length bay, which is effectively a shared lane. The zero-length case is included here to establish a boundary condition. The delay value becomes excessive when overflow occurs. This situation often degrades into oversaturation, and a proper assessment of delay would require a multiple-period analysis to account for the buildup of long-term queues.

Exhibit 31-57
Effect of Storage Bay Length on Throughput and Delay

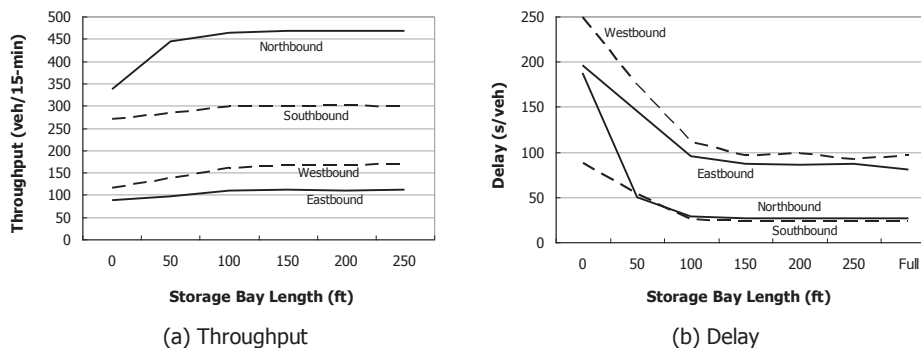

For case-specific applications, parameters that could influence the evaluation of bay overflow include the following:

- Number of lanes for each movement,
- Demand volumes for each movement,
- Impedance of left-turning vehicles by oncoming traffic during permitted periods,
- Signal-timing plan (cycle length and phase times),
- Factors that affect the number of left-turn sneakers for left-turn movements that have permitted operation, and
- Other factors that influence the saturation flow rates.

The example intersection described here had two through lanes in all directions. If only one through lane had existed, the blockage effect would have been much more severe.

Effect of Overflow on Through Movement Capacity

This subsection illustrates how an alternative tool can be used to model congestion due to storage bay overflow. An example was set up involving constant blockage of a through lane by left-turning vehicles. This condition arises only under very severe oversaturation.

The following variables are used for this examination:

- Cycle length is 90 s,
- Effective green time is 41 s, and
- Saturation flow rate is 1,800 veh/h/ln.

The approach has two through lanes. Traffic volumes were sufficient to overload both lanes, so that the number of trips processed by the simulation model was determined to be an indication of through movement capacity. With no storage bay overflow effect, this capacity is computed as 1,640 veh/h ($= 3,600 \times 41/90$). So, in a 15-min period, 410 trips were processed on average when there was no overflow.

Exhibit 31-58 shows the effect of the storage bay length on the through movement capacity. The percentage of the full capacity is plotted as a function of the storage bay length over the range of 0 to 600 ft. As expected, a zero-length bay reduces the capacity to 50% of its full value because one lane would be

constantly blocked. At the other extreme, the “no blockage” condition, achieved by setting the left-turn volume to zero, indicates the full capacity was available. The loss of capacity is more or less linear for storage lengths up to 600 ft, at which point about 90% of the full capacity is achieved.

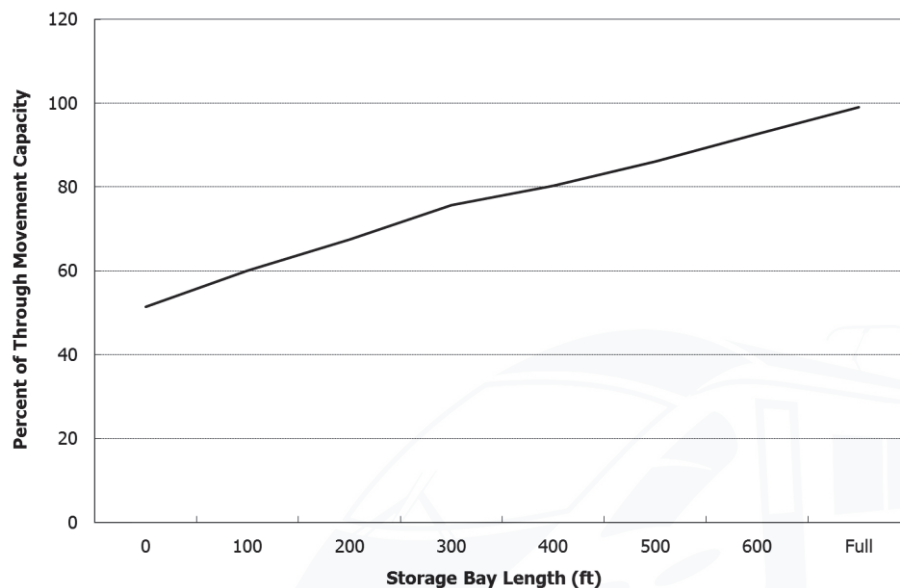

Exhibit 31-58
Effect of Storage Bay Length
on Capacity

Bay overflow is a very difficult phenomenon to deal with analytically, and a substantial variation in its treatment is expected among alternative tools. The main issue for modeling is the behavior of left-turning drivers denied access to the left-turn bay because of the overflow. The animated graphics display produced by some tools can often be used to examine this behavior and assess the tool’s validity. Typically, some model parameters can be adjusted so that the resulting behavior is more realistic.

EFFECT OF RIGHT-TURN-ON-RED OPERATION

The treatment of right-turn-on-red (RTOR) operation in the motorized vehicle methodology is limited to the removal of RTOR vehicles from the right-turn demand volume. If the right-turn movement is served by an exclusive lane, the methodology suggests RTOR volume can be estimated as equal to the left-turn demand of the complementary cross street left-turn movement, whenever this movement is provided a left-turn phase. Given the simplicity of this treatment, it may be preferable to use an alternative tool to evaluate RTOR operation under the following conditions:

- RTOR operation occurs at the intersection,
- Right turns are a critical element of the operation,
- An acceptable LOS depends on RTOR movements, or
- Detailed phasing alternatives involving RTOR are being considered.

The remainder of this subsection examines the RTOR treatment offered in the motorized vehicle methodology. The objective of this discussion is to illustrate when alternative tools should be considered.

Effect of Right-Turn Lane Allocation

This subsection examines the effect of the lane allocation for the right-turn movement. The lane-allocation scenarios considered include (a) provision of a shared lane for the right-turn movement and (b) provision of an exclusive right-turn lane. Exhibit 31-59 shows the results of the analysis. The intersection was simulated with (and without) the RTOR volume.

Exhibit 31-59
Effect of Right-Turn-on-Red and Lane Allocation on Delay

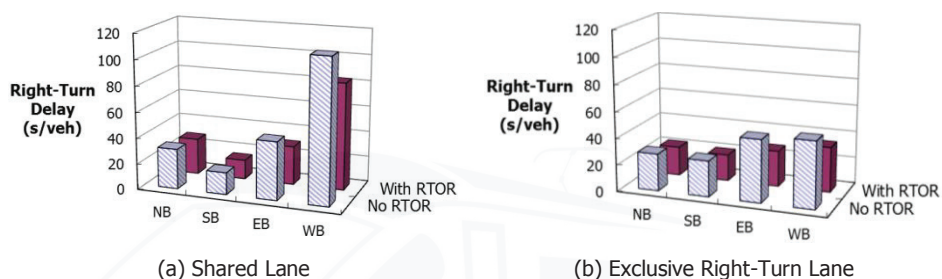

The trends in Exhibit 31-59 indicate there are only minimal differences in delay when RTOR is allowed relative to when it is not allowed. The northbound and southbound approaches had no shadowing opportunities because the eastbound and westbound movements did not have a protected left-turn phase. As a result, the effect of lane allocation and RTOR operation was negligible for the northbound and southbound right-turn movements.

In contrast, the eastbound and westbound right-turn movements were shadowed by the protected left-turn phases for the northbound and southbound approaches. As a result, the effect of lane allocation was more notable for the eastbound and the westbound right-turn movements.

Effect of Right-Turn Demand Volume

This subsection examines the effect of right-turn demand volume on right-turn delay, with and without RTOR allowed. The right-turn volumes varied from 100 to 400 veh/h on all approaches. Exclusive right-turn storage bays were provided on each approach.

The results are shown in Exhibit 31-60. They indicate delay to the northbound and southbound right-turn movements was fairly insensitive to right-turn volume, with or without RTOR allowed. The available green time on these approaches provided adequate capacity for the right turns. RTOR operation provided about a 25% delay reduction.

The delay to the eastbound and westbound right-turn movements increased rapidly with right-turn volume when RTOR was not allowed. At 300 veh/h and no RTOR, the right-turn delay becomes excessive in both directions. With RTOR, delay is less sensitive to right-turn volume. This trend indicates the additional capacity provided by RTOR is beneficial for higher right-turn volume levels.

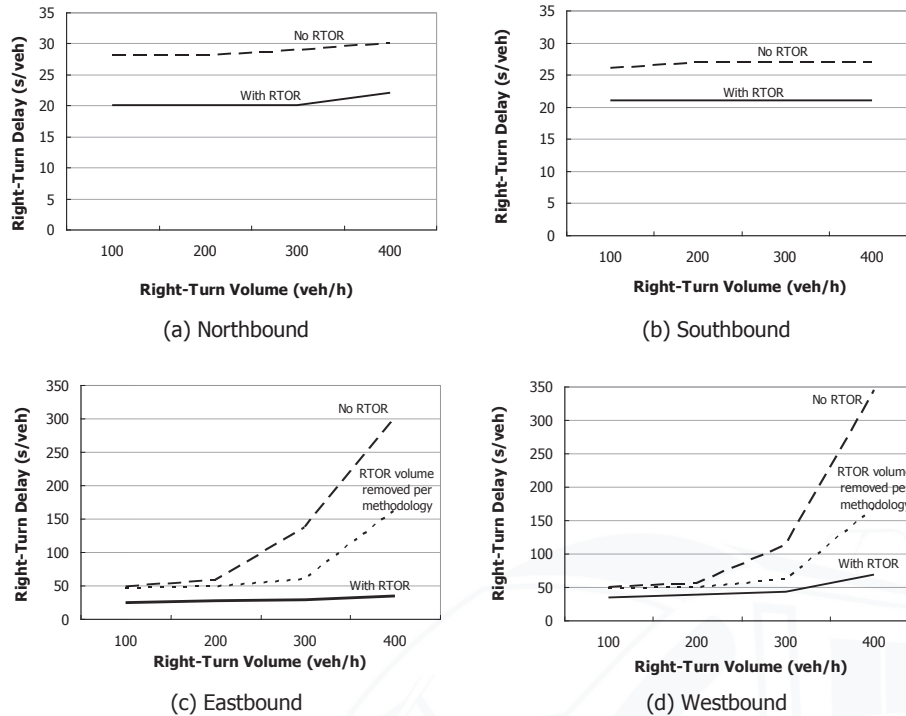

Exhibit 31-60
Effect of Right-Turn-on-Red and Right-Turn Volume on Delay

The treatment of RTOR suggested in the motorized vehicle methodology (i.e., removal of the RTOR vehicles from the right-turn volume) was also examined. The simulation analysis was repeated with the right-turn volumes reduced in this manner to explore the validity of this treatment.

The results of this analysis are shown in Exhibit 31-60 for the eastbound and westbound approaches. The trends shown suggest the treatment yields a result that is closer to the “with RTOR” case, as intended. However, use of the treatment in this case could still lead to erroneous conclusions about right-turn delay at intersections with high right-turn volumes.

Effect of a Protected Right-Turn Phase

This subsection compares the effect of adding a protected right-turn phase without RTOR allowed relative to just allowing RTOR. The example intersection was modified to include an exclusive right-turn storage bay and a protected right-turn phase for both the eastbound and westbound approaches. Each phase was timed concurrently with the complementary northbound or southbound left-turn phase, as appropriate. The results are shown in Exhibit 31-61. The trends in the exhibit indicate the protected phase does not improve over RTOR operation at low volume levels. However, it does provide some delay reduction at the high end of the volume scale.

Exhibit 31-61
Effect of Right-Turn-on-Red and Right-Turn Protection on Delay

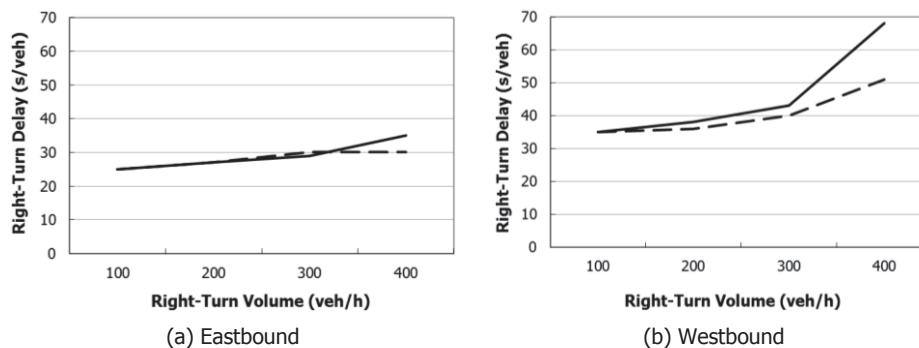

This examination indicates RTOR operation can have some effect on right-turn delay. The effect is most notable when there are no shadowing opportunities in the phase sequence for right-turn service or the right-turn volume is high. The use of an alternative tool to evaluate RTOR operation may provide a more realistic estimate of delay than simply removing RTOR vehicles from the right-turn demand volume, as suggested in Chapter 19.

EFFECT OF SHORT THROUGH LANES

One identified limitation of the motorized vehicle methodology is its inability to evaluate short through lanes that are added or dropped at the intersection. This subsection describes the results from an evaluation of this geometry for the purpose of illustrating the effect of short through lanes.

Several alternative tools can address the effect of short through lanes. Each tool will have its own unique method of representing lane drop or add geometry and models of driver behavior. Some degree of approximation is involved with all evaluation tools.

The question under consideration is, “How much additional through traffic could the northbound approach accommodate if a lane were added both 150 ft upstream and 150 ft downstream of the intersection?” The capacity of the original two northbound lanes was computed as 1,778 veh/h (i.e., 889 veh/h/ln) by using the motorized vehicle methodology. The simulation tool’s start-up lost time and saturation headway parameters were then adjusted so the simulation tool produced the same capacity. It was found in this case that a 2.3-s headway and 3.9-s start-up lost time produced the desired capacity.

Finally, the additional through lane was added to the simulated intersection, and the process of determining capacity was repeated. On the basis of an average of 30 runs, the capacity of the additional lane was computed as 310 veh/h. Theoretically, the addition of a full lane would increase the capacity by another 889 veh/h, for a total of 2,667 veh/h.

The alternative tool indicates the additional lane contributes only 0.35 equivalent lane (= 310/889). This result cannot be stated as a general conclusion that applies to all cases because other parameters (such as the signal-timing plan and the proportion of right turns in the lane group) will influence the results. More important, the results are likely to vary among alternative tools given the likely differences in their driver behavior models.

EFFECT OF CLOSELY SPACED INTERSECTIONS

The effect of closely spaced intersections is examined in this subsection. The motorized vehicle methodology does not account for the effect of queue cyclic spillback from a downstream signal or demand starvation from an upstream signal. It is generally accepted that simulation of these effects is desirable when two closely spaced signalized intersections interact with each other in this manner.

Consider two intersections separated by 200 ft along the north–south roadway. They operate with the same cycle length and the same northbound and southbound green time. To keep the problem simple, only through movements are allowed at these intersections. The northbound approach is used in this discussion to illustrate the effect of the adjacent intersection. The layout of this system and the resulting lane blockage are illustrated in Exhibit 31-62.

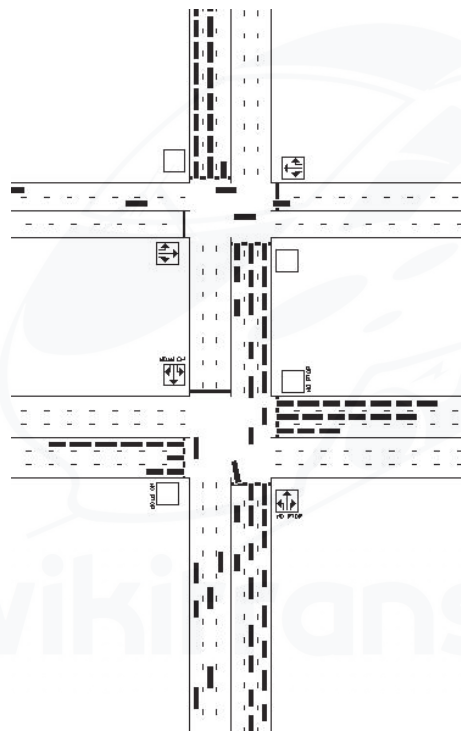

Exhibit 31-62
Closely Spaced Intersections

Exhibit 31-62 illustrates both cyclic spillback and demand starvation at one point in the cycle. For the northbound direction, traffic queues have spilled back from the downstream intersection to block the upstream intersection. For the southbound direction, the traffic at the upstream intersection is prevented from reaching the downstream intersection by the red signal at the upstream intersection. Valuable green time is being wasted in both travel directions at the southern intersection.

Exhibit 31-63 illustrates the relationship between signal offset and the performance of the northbound travel direction. In terms of capacity, the exhibit shows that under the best-case condition (i.e., zero offset), the capacity is maintained at a value slightly above the demand volume. Under the worst-case

Exhibit 31-63
Effect of Closely Spaced
Intersections on Capacity and
Delay

condition, the capacity is reduced to slightly below 1,000 veh/h. The demand volume-to-capacity ratio under this condition is about 1.7.

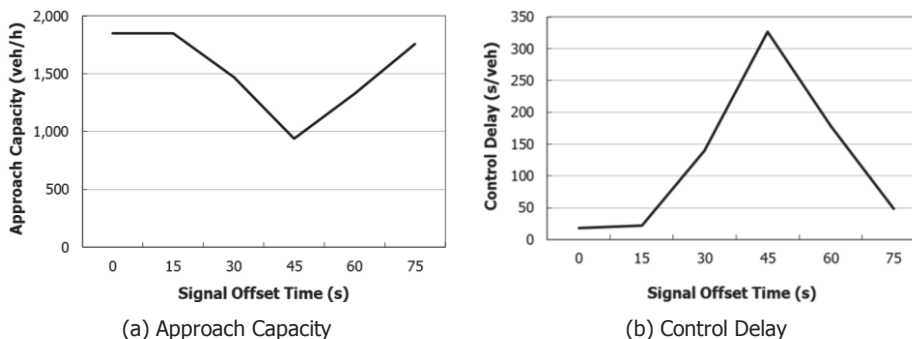

The effect of signal offset time on the delay to northbound traffic approaching the first intersection is also shown in Exhibit 31-63. As expected, the delay is minimal under favorable offsets, but it increases rapidly as the offset becomes less favorable. Delay is at its maximum value with a 45-s offset time. The large value of delay suggests that approach is severely oversaturated.

The delay reported by most simulation tools represents the delay incurred by vehicles when they *depart* the system during the analysis period, as opposed to the delay incurred by vehicles that *arrive* during the analysis period. The latter measure represents the delay reported by the motorized vehicle methodology.

For oversaturated conditions, the delay reported by a simulation tool may be biased when the street system is not adequately represented. This bias occurs when the street system represented to the tool does not physically extend beyond the limits of the longest queue that occurs during the analysis period.

The issues highlighted in the preceding paragraphs must be considered when an alternative tool is used. Specifically, a multiple-period analysis must be conducted that temporally spans the period of oversaturation. Also, the spatial boundaries of the street system must be large enough to encompass all queues during the saturated time periods. A more detailed discussion of multiple-period analyses is presented in Chapter 7, Interpreting HCM and Alternative Tool Results.

9. EXAMPLE PROBLEMS

This section describes the application of each of the motorized vehicle, pedestrian, and bicycle methodologies through the use of example problems. Exhibit 31-64 provides an overview of these problems. The examples focus on the operational analysis level. The planning and preliminary engineering analysis level is identical to the operational analysis level in terms of the calculations, except that default values are used when field-measured values are not available.

Problem Number	Description	Analysis Level
1	Motorized vehicle LOS	Operational
2	Pedestrian LOS	Operational
3	Bicycle LOS	Operational

Exhibit 31-64
Example Problems

EXAMPLE PROBLEM 1: MOTORIZED VEHICLE LOS

The Intersection

The intersection of 5th Avenue and 12th Street is an intersection of two urban arterial streets. The intersection plan view is shown in Exhibit 31-65.

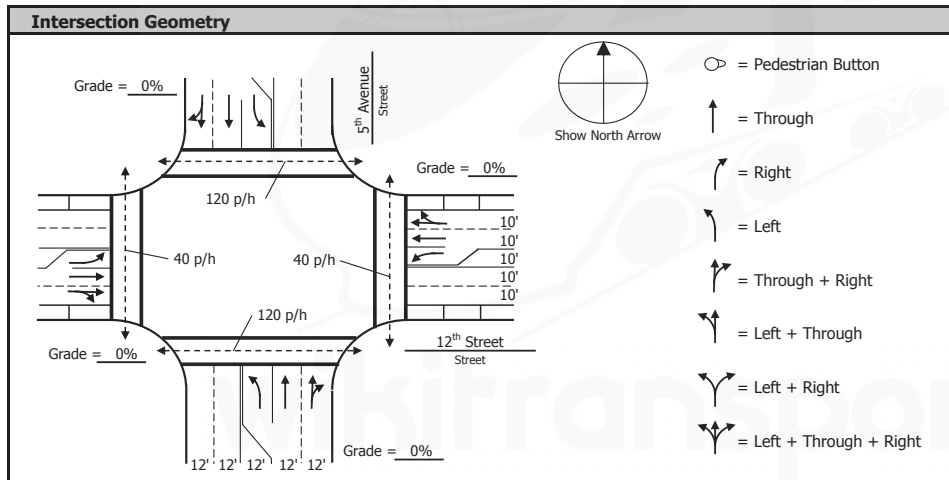

Exhibit 31-65
Example Problem 1:
Intersection Plan View

The Question

What is the motorist delay and LOS during the analysis period for each lane group and the intersection as a whole?

The Facts

The intersection's traffic, geometric, and signalization conditions are listed in Exhibit 31-66, Exhibit 31-67, and Exhibit 31-68, respectively. Exhibit 31-69 presents additional data. The volume data provided represent the demand flow rate during the 0.25-h analysis period, so a peak hour factor is not applicable to this evaluation.

Exhibit 31-66
Example Problem 1: Traffic Characteristics Data

Input Data Element	Eastbound			Westbound			Northbound			Southbound		
	L	T	R	L	T	R	L	T	R	L	T	R
Demand flow rate (veh/h)	71	318	106	118	600	24	133	1644	111	194	933	111
RTOR flow rate (veh/h)			0			0			22			33
Percentage heavy vehicles (%)	5	5		5	5		2	2		2	2	
Platoon ratio	1.00	1.00		1.00	1.00		1.00	1.00		1.00	1.00	
Upstream filtering adjustment factor	1.00	1.00		1.00	1.00		1.00	1.00		1.00	1.00	
Initial queue (veh)	0	0		0	0		0	0		0	0	
Base saturation flow rate (pc/h/ln)	1,900	1,900		1,900	1,900		1,900	1,900		1,900	1,900	
Pedestrian flow rate (p/h)		120			120			40			40	
Bicycle flow rate (bicycles/h)		0			0			0			0	
On-street parking maneuver rate (maneuvers/h)		5			5							
Local bus stopping rate (buses/h)		0			0			0			0	

Note: L = left turn; T = through; R = right turn.

Exhibit 31-67
Example Problem 1: Geometric Design Data

Input Data Element	Eastbound			Westbound			Northbound			Southbound		
	L	T	R	L	T	R	L	T	R	L	T	R
Number of lanes (ln)	1	2	0	1	2	0	1	2	0	1	2	0
Average lane width (ft)	10.0	10.0		10.0	10.0		12.0	12.0		12.0	12.0	
Number of receiving lanes (ln)		2			2			2			2	
Turn bay length (ft)	200			200			200			200		
Presence of on-street parking	No		Yes	No		Yes	No		No	No		No
Approach grade (%)		0			0			0			0	

Note: L = left turn; T = through; R = right turn.

Exhibit 31-68
Example Problem 1: Signal Control Data

Input Data Element	Eastbound	Westbound	Northbound	Southbound
Type of signal control	Actuated	Actuated	Actuated	Actuated
Phase sequence	No left-turn phase	No left-turn phase	Leading left	Lagging left
Phase number	2	6	3	7
Movement	L+T+R	L+T+R	L T+R	L T+R
Left-turn operational mode	Perm.	Perm.	Prot.-Perm.	Prot.-Perm.
Dallas left-turn phasing option			No	No
Passage time (s)	2.0	2.0	2.0	2.0
Maximum green (s)	30	30	25	50
Minimum green (s)	5	5	5	5
Yellow change (s)	4.0	4.0	4.0	4.0
Red clearance (s)	0	0	0	0
Walk (s)	5	5	5	5
Pedestrian clear (s)	14	14	16	16
Phase recall	No	No	No	No
Dual entry	Yes	Yes	No	Yes
Simultaneous gap-out		Yes		Yes

Note: L = left turn; T = through; R = right turn; Prot. = protected; Perm. = permitted.

Input Data Element	Eastbound			Westbound			Northbound			Southbound		
	L	T	R	L	T	R	L	T	R	L	T	R
Analysis period duration (h)	0.25			0.25			0.25			0.25		
Speed limit (mi/h)	35			35			35			35		
Stop-line detector length (ft)	40	40		40	40		40	40		40	40	
Detection mode	Pres.	Presence		Pres.	Presence		Pres.	Presence		Pres.	Presence	
Area type	Central business district											

Exhibit 31-69
Example Problem 1: Other Data

Note: L = left turn; T = through; R = right turn; Pres. = presence.

The intersection is located in a central business district-type environment. Adjacent signals are somewhat distant so the intersection is operated by using fully actuated control. Vehicle arrivals to each approach are characterized as “random” and are described by using a platoon ratio of 1.0.

The left-turn movements on the north-south street operate under protected-permitted control and lead the opposing through movements (i.e., a lead-lead phase sequence). The left-turn movements on the east-west street operate as permitted.

All intersection approaches have a 200-ft left-turn bay, an exclusive through lane, and a shared through and right-turn lane. The average width of the traffic lanes on the east-west street is 10 ft. The average width of the traffic lanes on the north-south street is 12 ft.

Crosswalks are provided on each intersection leg. A two-way flow rate of 120 p/h is estimated to use each of the east-west crosswalks and a two-way flow rate of 40 p/h is estimated to use each of the north-south crosswalks.

On-street parking is present on the east-west street. It is estimated that parking maneuvers on each intersection approach occur at a rate of 5 maneuvers/h during the analysis period.

The speed limit is 35 mi/h on each intersection approach. The analysis period is 0.25 h. There is no initial queue for any movement.

As noted in the next section, none of the intersection movements have two or more exclusive lanes. For this reason, the saturation flow rate adjustment factor for lane utilization is not applicable. Any unequal lane use that may occur due to the shared through and right-turn lane groups will be accounted for in the lane group flow rate calculation, as described in the Lane Group Flow Rate on Multiple-Lane Approaches subsection of Section 2.

Outline of Solution

The solution follows the steps listed in Exhibit 19-18 of Chapter 19.

Step 1: Determine Movement Groups and Lane Groups

The left-turn lanes are designated as separate movement groups according to the rules described in Chapter 19. The through and shared right-turn and through lanes are combined into one movement group on each approach. The movement group designations are shown in Exhibit 31-70a with brackets showing how the individual movements are combined into movement groups.

Exhibit 31-70
Example Problem 1:
Movement Groups and Lane Groups

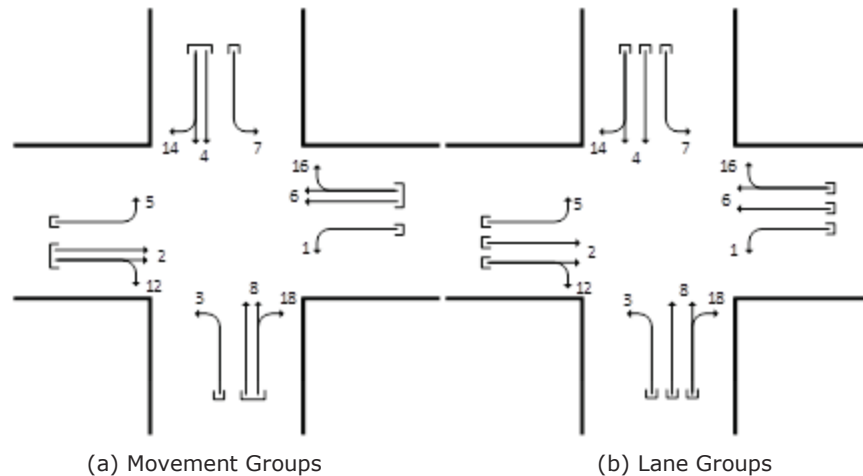

Each lane is analyzed as a separate lane group according to the rules in Chapter 19. The lane group designations are shown in Exhibit 31-70b with brackets showing how the individual lanes are combined into lane groups.

Step 2: Determine Movement Group Flow Rate

Exhibit 31-71 shows the movement group flow rates, which are based on the movement groups identified in Exhibit 31-70a. The RTOR flow rate is subtracted from the right-turn volume for the northbound and southbound through-and-right-turn movement groups.

Exhibit 31-71
Example Problem 1:
Movement Group Flow Rates

Data Element	Eastbound		Westbound		Northbound		Southbound	
	L	T+R	L	T+R	L	T+R	L	T+R
Movement group	L	T+R	L	T+R	L	T+R	L	T+R
Number of lanes (ln)	1	2	1	2	1	2	1	2
Movement group flow rate (veh/h)	71	318 + 106 = 424	118	600 + 24 = 624	133	1,644 + 111 - 22 = 1,733	194	933 + 111 - 33 = 1,011

Note: L = left turn; T+R = combined through and right turn.

Step 3: Determine Lane Group Flow Rate

There is one shared lane and two or more lanes on each intersection approach. For this configuration, the lane group flow rates for the through-and-right-turn movement groups are computed by the procedures in the Lane Group Flow Rate on Multiple-Lane Approaches subsection of Section 2. The results of these calculations are given in Exhibit 31-72. The left-turn lane group volumes remain unchanged from Exhibit 31-71 because the movement groups and the lane groups are the same for the left-turn lanes. The volumes shown for the through lane group and the shared lane group represent the flow rates obtained from the Section 2 procedure.

Exhibit 31-72
Example Problem 1: Lane
Group Flow Rates

Data Element	Eastbound			Westbound			Northbound			Southbound		
	L	T	T+R	L	T	T+R	L	T	T+R	L	T	T+R
Lane group	L	T	T+R	L	T	T+R	L	T	T+R	L	T	T+R
Number of lanes (ln)	1	1	1	1	1	1	1	1	1	1	1	1
Flow rate (veh/h)	71	239	185	118	337	287	133	870	863	194	513	497

Note: L = left turn; T = through; T+R = combined through and right turn.

Step 4: Determine Adjusted Saturation Flow Rate

The base saturation flow rate is 1,900 veh/h/ln for each lane group. Adjustments made for each of the lane groups are summarized in the following paragraphs.

The left-turn lane groups for the eastbound and westbound approaches operate with the permitted mode. The saturation flow rate of a permitted left-turn movement s_p is determined with Equation 31-100. For example, the saturation flow rate for the eastbound left-turn lane group is computed with the following equation.

$$s_p = \frac{v_o e^{-v_o t_{cg}/3,600}}{1 - e^{-v_o t_{fh}/3,600}} = \frac{624 e^{-624(4.5)/3,600}}{1 - e^{-624(2.5)/3,600}} = 813 \text{ veh/h/ln}$$

The adjustment factor for the existence of parking and parking activity f_p is applied to the shared-lane lane groups for the eastbound and westbound approaches. This factor is computed with Equation 19-11.

The adjustment factor for area type f_a is applied to all lane groups. Guidance for determining this factor's value is provided in Section 3 of Chapter 19 (in the subsection titled Adjustment for Area Type).

The adjustment factor for heavy vehicles and grade f_{HVg} is computed with Equation 19-10. This factor is applicable to all lane groups.

The adjustment factors and the adjusted saturation flow rate for each movement are shown in Exhibit 31-73.

Data Element	Eastbound			Westbound			Northbound			Southbound		
	L	T	T+R	L	T	T+R	L	T	T+R	L	T	T+R
Phase number	2	2	2	6	6	6	3	8	8	7	4	4
Base saturation flow rate s_o (pc/h/ln)		1,900	1,900		1,900	1,900	1,900	1,900	1,900	1,900	1,900	1,900
Permitted left turn saturation flow rate s_p (veh/h/ln)	813			978								
Adjustment factor for left-turn vehicle presence, f_{LT}							0.95			0.95		
Adjustment factor for heavy vehicles and grade, f_{HVg}	0.96	0.96	0.96	0.96	0.96	0.96	0.98	0.98	0.98	0.98	0.98	0.98
Adjustment factor for existence of parking lane and parking activity, f_p			0.88			0.88						
Adjustment factor for area type, f_a	0.90	0.90	0.90	0.90	0.90	0.90	0.90	0.90	0.90	0.90	0.90	0.90
Pedestrian adjustment factor for left-turn groups, f_{Lpb}	1.00			0.98			1.00			1.00		
Pedestrian-bicycle adjustment factor for right-turn groups, f_{Rpb}			0.88			0.88			0.98			0.98
Adjusted saturation flow rate (veh/h/ln)	702	1,643	1,201	825	1,643	1,398	1,603	1,683	1,648	1,603	1,683	1,630

Exhibit 31-73
Example Problem 1: Adjusted Saturation Flow Rate

Notes: L = left turn; T = through; T+R = combined through and right turn.
Calculated values are based on maintaining six or more significant digits for all computed values through all calculations. These values are shown with fewer digits for presentation purposes only.

Equation 19-8 shows all the adjustment factors that might be applied in the calculation of saturation flow rate. However, when this equation is applied to a given lane group, some of the factors are not applicable (or have a value of 1.0) and can be removed from the equation. The reduced form of the saturation flow rate equation is described in the following paragraphs for several of the lane groups at the subject intersection.

For the eastbound and westbound left-turn lane groups, the adjusted saturation flow rate is calculated with the following equation.

$$s = s_p f_{HVg} f_a f_{Lpb}$$

The northbound and southbound left-turn lane groups operate in the protected-permitted mode. The adjusted saturation flow rate for the protected left-turn phase is calculated with the following equation.

$$s = s_o f_{LT} f_{HVg} f_a$$

The adjusted saturation flow rate for the permitted left-turn period is calculated with the same equation as for the eastbound and westbound left-turn lane groups.

For the through lane groups on each approach, the adjusted saturation flow rate is computed with the following equation.

$$s = s_o f_{HVg} f_a$$

For the shared-lane lane groups, the adjusted saturation flow rate is computed by using Equation 31-105. This equation is reproduced below for the eastbound shared right-turn and through lane group.

$$s_{sr} = \frac{s_{th}}{1 + P_R \left(\frac{E_R}{f_{Rpb}} - 1 \right)} = \frac{1,438}{1 + \left(\frac{106}{186} \right) \left(\frac{1.18}{0.88} - 1 \right)} = 1,201 \text{ veh/h/ln}$$

with

$$s_{th} = s_o f_{HVg} f_p f_a = 1,900 \times 0.96 \times 0.88 \times 0.90 = 1,438 \text{ veh/h/ln}$$

The calculated adjustment factors and saturation flow rates in the previous equations are based on maintaining six or more significant digits for all computed values through all calculations. These values are shown with fewer digits for presentation purposes only.

Step 5: Determine Proportion Arriving During Green

The proportion arriving during green *P* is computed using Equation 19-15. The results are shown in Exhibit 31-74. The effective green time *g* and cycle length *C* are determined by using the results from the final iteration of Step 6.

Exhibit 31-74
Example Problem 1:
Proportion Arriving During
Green

Data Element	Eastbound			Westbound			Northbound			Southbound		
Lane group	L	T	T+R	L	T	T+R	L	T	T+R	L	T	T+R
Phase number	2	2	2	6	6	6	3	8	8	7	4	4
Effective green time <i>g</i> (s)	30.0	30.0	30.0	30.0	30.0	30.0	6.2	50.0	50.0	9.8	53.6	53.6
Proportion arriving on green, <i>P</i>	0.29	0.29	0.29	0.29	0.29	0.29	0.06	0.49	0.49	0.10	0.53	0.53

Note: L = left turn; T = through; T+R = combined through and right turn.
Calculated values are based on maintaining six or more significant digits for all computed values through all calculations. These values are shown with fewer digits for presentation purposes only.

Step 6: Determine Signal Phase Duration

The duration of each signal phase is determined by using the procedure described in Section 2 (in the subsection titled Actuated Phase Duration). The results of this iterative process are shown in Exhibit 31-75. The resulting cycle length is 101.8 s.

Data Element	Eastbound	Westbound	Northbound		Southbound	
Phase number	2	6	3	8	7	4
Assigned movements	L+T+R	L+T+R	L	T+R	L	T+R
Phase duration D_p (s)	34.0	34.0	10.2	54.0	13.8	57.6
Maximum allowable headway MAH (s)	3.4	3.4	3.1	3.1	3.1	3.1
Maximum queue clearance time g_c (s)	28.7	27.2	4.1	50.0	7.6	21.2
Green extension time g_e (s)	0.0	0.4	0.2	0.0	0.3	7.8
Probability that subject phase is called, p_c	1.00	1.00	0.98	1.00	1.00	1.00
Probability of max-out, p_x	1.00	1.00	0.0	1.00	0.0	0.18
Duration of permitted left-turn green not blocked by an opposing queue, g_u (s)	11.4	17.0	32.5		0.0	

Exhibit 31-75
Example Problem 1: Signal Phase Duration

Notes: L = left turn; T = through; T+R = combined through and right turn; L+T+R = combined left, through, and right turn.
Calculated values are based on maintaining six or more significant digits for all computed values through all calculations. These values are shown with fewer digits for presentation purposes only.

Step 7: Determine Capacity and Volume-to-Capacity Ratio

The capacity of each through lane group and each shared-lane lane group is computed with Equation 19-16. The capacity for the permitted left-turn lane groups is computed with Equation 31-119. The latter equation is reproduced below for the eastbound left-turn lane group.

$$c_{l,e} = \frac{g_u s_l + 3,600 n_s f_{ms} f_{sp}}{C} N_l$$

$$c_{l,e} = \frac{(11.4 \times 702) + (3,600 \times 2 \times 1.0 \times 1.0)}{101.8} \times 1 = 149 \text{ veh/h}$$

The capacity for the protected-permitted left-turn lane groups on the northbound and southbound approaches is computed with Equation 31-124. The results from the capacity and the volume-to-capacity ratio calculations are shown in Exhibit 31-76.

Data Element	Eastbound			Westbound			Northbound			Southbound		
Lane group	L	T	T+R	L	T	T+R	L	T	T+R	L	T	T+R
Phase number	2	2	2	6	6	6	3	8	8	7	4	4
Number of lanes N (ln)	1	1	1	1	1	1	1	1	1	1	1	1
Flow rate v (veh/h)	71	239	185	118	337	287	133	870	863	194	513	497
Adjusted saturation flow rate s (veh/h/ln)	702	1,643	1,201	825	1,643	1,398	1,603	1,683	1,648	1,603	1,683	1,630
Effective green time g (s)	30.0	30.0	30.0	30.0	30.0	30.0	6.2	50.0	50.0	9.8	53.6	53.6
Capacity c (veh/h)	149	484	354	208	484	412	328	827	809	225	887	859
Volume-to-capacity ratio X	0.47	0.49	0.52	0.57	0.70	0.70	0.41	1.05	1.07	0.86	0.58	0.58

Exhibit 31-76
Example Problem 1: Capacity and Volume-to-Capacity Ratio

Note: L = left turn; T = through; T+R = combined through and right turn.
Calculated values are based on maintaining six or more significant digits for all computed values through all calculations. These values are shown with fewer digits for presentation purposes only.

Exhibit 31-77

Example Problem 1: Control Delay

Step 8: Determine Delay

The control delay for each movement and approach, and for the intersection as a whole, is calculated with Equation 19-18. The results of the delay calculations are shown in Exhibit 31-77.

Data Element	Eastbound			Westbound			Northbound			Southbound		
	L	T	T+R	L	T	T+R	L	T	T+R	L	T	T+R
Lane group	L	T	T+R	L	T	T+R	L	T	T+R	L	T	T+R
Phase number	2	2	2	6	6	6	3	8	8	7	4	4
Uniform delay d_1 (s/veh)	44.6	29.6	29.9	41.3	31.9	31.9	13.2	25.9	25.9	28.9	16.4	16.4
Incremental delay d_2 (s/veh)	0.9	0.3	0.7	2.3	3.6	4.3	0.3	46.0	50.8	3.8	0.6	0.7
Initial queue delay d_3 (s/veh)	0.0	0.0	0.0	0.0	0.0	0.0	0.0	0.0	0.0	0.0	0.0	0.0
Control delay d (s/veh)	45.5	29.9	30.6	43.5	35.5	36.2	13.5	72.0	76.7	32.6	17.0	17.1
Level of service	D	C	C	D	D	D	B	F	F	C	B	B
Approach delay d_A (s/veh)		32.4			37.0			70.0			19.6	
Approach LOS		C			D			E			B	
Intersection delay d_i (s/veh)							45.9					
Intersection LOS							D					

Note: L = left turn; T = through; T+R = combined through and right turn.

Calculated values are based on maintaining six or more significant digits for all computed values through all calculations. These values are shown with fewer digits for presentation purposes only.

Step 9: Determine LOS

LOS is based on the control delay. LOS values for each approach and for the entire intersection are shown in Exhibit 31-77. The determination of LOS is based on the LOS thresholds in Exhibit 19-8.

Step 10: Determine Queue Storage Ratio

The procedure for calculating the percentile back-of-queue size and queue storage ratio is described in Section 4. This procedure was used to compute the 50th percentile values for both variables. The results are shown in Exhibit 31-78.

Exhibit 31-78

Example Problem 1: Back of Queue and Queue Storage Ratio

Data Element	Eastbound			Westbound			Northbound			Southbound		
	L	T	T+R	L	T	T+R	L	T	T+R	L	T	T+R
Lane group	L	T	T+R	L	T	T+R	L	T	T+R	L	T	T+R
Phase number	2	2	2	6	6	6	3	8	8	7	4	4
50th percentile back of queue Q_{50} (veh/ln)	1.8	4.8	3.8	3.0	7.6	6.6	1.4	28.9	29.4	4.9	7.7	7.5
50th percentile queue storage ratio $R_{Q_{50}}$	0.23	0.12	0.10	0.38	0.20	0.17	0.18	0.74	0.75	0.62	0.20	0.19

Note: L = left turn; T = through; T+R = combined through and right turn.

Queue Accumulation Polygon

The QAP is a useful way of illustrating the signal timing and performance of a signalized intersection. The evolution of the queue length during the cycle is shown in the QAP. In addition, the area of the QAP is the total uniform delay experienced by all vehicles during the cycle. The variables needed to construct the QAP for the northbound through lane group are provided in the following list. The QAP for this movement is shown in Exhibit 31-79.

- Flow rate: 870 veh/h,
- Adjusted saturation flow rate: 1,683 veh/h/ln,
- Cycle length: 101.8 s,
- Effective green time: 50.0 s,

- Effective red time: 51.8 s,
- Maximum queue clearance time: 50.0 s,
- Green extension time: 0.0 s, and
- Queue length at end of effective red: 13.4 veh/ln.

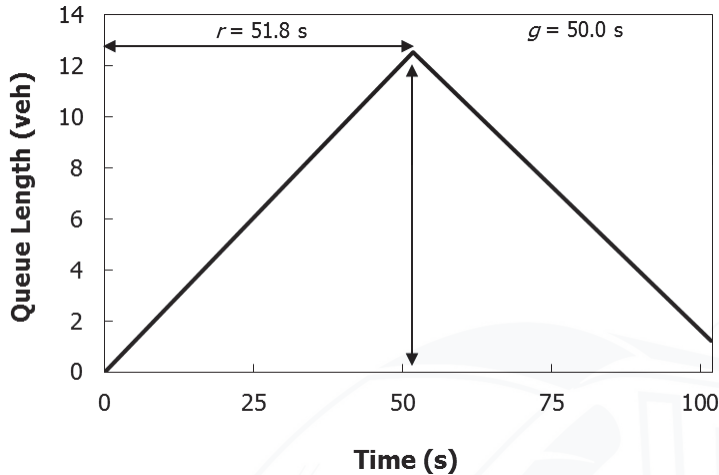

Exhibit 31-79
Example Problem 1: Queue Accumulation Polygon

EXAMPLE PROBLEM 2: PEDESTRIAN LOS

The Intersection

The pedestrian crossing of interest crosses the north leg at a signalized intersection. The north-south street is the minor street and the east-west street is the major street. The intersection serves all north-south traffic concurrently (i.e., no left-turn phases) and all east-west traffic concurrently. The signal has an 80-s cycle length. The crosswalk and intersection corners that are the subject of this example problem are shown in Exhibit 31-80.

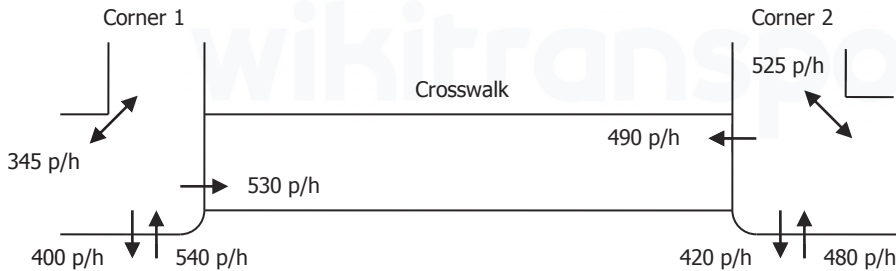

Exhibit 31-80
Example Problem 2: Pedestrian Flow Rates

The Question

What is the pedestrian LOS for the crossing?

The Facts

Pedestrian flow rates are shown in Exhibit 31-80. Vehicular flow rates are shown in Exhibit 31-81.

Exhibit 31-81
 Example Problem 2: Vehicular
 Demand Flow Rates

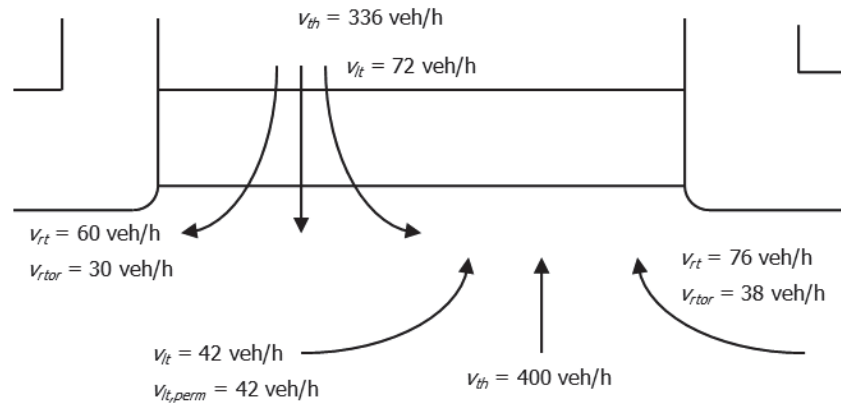

In addition, the following facts are known about the crosswalk and the intersection corners:

- Major street: Phase duration, $D_{p,mj} = 48$ s
 Yellow change interval, $Y_{mj} = 4$ s
 Red clearance interval, $R_{mj} = 1$ s
 Walk setting, $Walk_{mj} = 7$ s
 Pedestrian clear setting, $PC_{mj} = 8$ s
 Four traffic lanes (no turn bays)
- Minor street: Phase duration, $D_{p,mi} = 32$ s
 Yellow change interval, $Y_{mi} = 4$ s
 Red clearance interval, $R_{mi} = 1$ s
 Walk setting, $Walk_{mi} = 7$ s
 Pedestrian clear setting, $PC_{mi} = 13$ s
 Two traffic lanes (no turn bays)
 85th percentile speed at a midsegment location, $S_{85,mi} = 35$ mi/h
- Corner 1: Total walkway width, $W_a = W_b = 16$ ft
 Corner radius, $R = 15$ ft
- Corner 2: Total walkway width, $W_a = W_b = 18$ ft
 Corner radius, $R = 15$ ft
- Other data: Effective crosswalk width, $W_c = 16$ ft
 Crosswalk length, $L_c = 28$ ft
 Walking speed, $S_p = 4$ ft/s
 No right-turn channelizing islands are provided on any corner.
 Pedestrian signal indications are provided for each crosswalk.
 Rest-in-walk mode is not used for any phase.

Comments

On the basis of the variable notation in Exhibit 19-29, the subject crosswalk is Crosswalk C because it crosses the minor street. The outbound pedestrian flow rate v_{co} at Corner 1 equals inbound flow rate v_{ci} at Corner 2, and the inbound flow rate v_{ci} at Corner 1 equals the outbound flow rate v_{co} at Corner 2.

Outline of Solution

First, the circulation area is calculated for both corners. Next, the circulation area is calculated for the crosswalk. The street corner and crosswalk circulation areas are then compared with the qualitative descriptions of pedestrian space listed in Exhibit 19-28.

Pedestrian delay and the pedestrian LOS score are then calculated for the crossing. Finally, LOS for the crossing is determined on the basis of the computed score and the threshold values in Exhibit 19-9.

Computational Steps

The solution follows the steps listed in Exhibit 19-33 of Chapter 19.

Step 1: Determine Street Corner Circulation Area

A. Compute Available Time-Space

For Corner 1, the available time-space is computed with Equation 19-51.

$$\begin{aligned} TS_{\text{corner}} &= C(W_a W_b - 0.215 R^2) \\ TS_{\text{corner}} &= 80[16 \times 16 - 0.215(15)^2] \\ TS_{\text{corner}} &= 16,610 \text{ ft}^2\text{-s} \end{aligned}$$

B. Compute Holding-Area Waiting Time

Because pedestrian signal indications are provided and rest-in-walk is not enabled, the effective walk time for the phase serving the major street is computed with Equation 19-54.

$$\begin{aligned} g_{\text{Walk,mj}} &= \text{Walk}_{mj} + 4.0 \\ g_{\text{Walk,mj}} &= 7.0 + 4.0 = 11 \text{ s} \end{aligned}$$

The number of pedestrians arriving at the corner during each cycle to cross the minor street is computed with Equation 19-53.

$$\begin{aligned} N_{co} &= \frac{v_{co}}{3,600} C \\ N_{co} &= \frac{530}{3,600} (80) = 11.8 \text{ p} \end{aligned}$$

The total time spent by pedestrians waiting to cross the minor street during one cycle is then calculated with Equation 19-52.

$$\begin{aligned} Q_{tco} &= \frac{N_{co}(C - g_{\text{Walk,mj}})^2}{2C} \\ Q_{tco} &= \frac{(11.8)(80 - 11)^2}{2(80)} = 350.5 \text{ p-s} \end{aligned}$$

By the same procedure, the total time spent by pedestrians waiting to cross the major street during one cycle (Q_{tdo}) is found to be 264.5 p-s.

C. Compute Circulation Time–Space

The circulation time–space is found by using Equation 19-57.

$$TS_c = TS_{\text{corner}} - [5.0(Q_{tdo} + Q_{tco})]$$

$$TS_c = 16,610 - [5.0(350.5 + 264.5)] = 13,535 \text{ ft}^2\text{-s}$$

D. Compute Pedestrian Corner Circulation Area

The total number of circulating pedestrians is computed with Equation 19-59.

$$N_{\text{tot}} = \frac{v_{ci} + v_{co} + v_{di} + v_{do} + v_{a,b}}{3,600} C$$

$$N_{\text{tot}} = \frac{490 + 530 + 540 + 400 + 345}{3,600} (80) = 51.2 \text{ p}$$

Finally, the corner circulation area per pedestrian is calculated with Equation 19-58.

$$M_{\text{corner}} = \frac{TS_c}{4.0 N_{\text{tot}}}$$

$$M_{\text{corner}} = \frac{13,535}{4.0(51.2)} = 66.1 \text{ ft}^2/\text{p}$$

By following the same procedure, the corner circulation area per pedestrian for Corner 2 is found to be 87.6 ft²/p. According to the qualitative descriptions provided in Exhibit 19-28, pedestrians at both corners will have the ability to move in the desired path without needing to alter their movements to avoid conflicts.

Step 2: Determine Crosswalk Circulation Area

The analysis conducted in this step describes the circulation area for pedestrians in the subject crosswalk.

A. Establish Walking Speed

As given in the subsection titled The Facts, the average walking speed is determined to be 4.0 ft/s.

B. Compute Available Time–Space

Rest-in-walk is not enabled, so the pedestrian service time g_{ped} is estimated to equal the sum of the walk and pedestrian clear settings. The time–space available in the crosswalk is found with Equation 19-60.

$$TS_{cw} = L_c W_c g_{\text{Walk},mj}$$

$$TS_{cw} = (28)(16)(11) = 4,928 \text{ ft}^2\text{-s}$$

C. Compute Effective Available Time–Space

The number of turning vehicles during the walk and pedestrian clear intervals is calculated with Equation 19-63.

$$N_{tv} = \frac{v_{lt,perm} + v_{rt} - v_{rtor}}{3,600} C$$

$$N_{tv} = \frac{42 + 76 - 38}{3,600} (80) = 1.8 \text{ veh}$$

The time-space occupied by turning vehicles can then be computed with Equation 19-62.

$$TS_{tv} = 40 N_{tv} W_c$$

$$TS_{tv} = 40(1.8)(16) = 1,138 \text{ ft}^2\text{-s}$$

The effective available crosswalk time-space TS_{cw}^* is found by subtracting the total available crosswalk time-space TS_{cw} from the time-space occupied by turning vehicles, as shown by Equation 19-61.

$$TS_{cw}^* = TS_{cw} - TS_{tv}$$

$$TS_{cw}^* = 4,928 - 1,138 = 3,970 \text{ ft}^2\text{-s}$$

D. Compute Pedestrian Service Time

The number of pedestrians exiting the curb when the WALK indication is presented is computed by using Equation 19-66.

$$N_{ped,co} = N_{co} \frac{C - g_{Walk,mj}}{C}$$

$$N_{ped,co} = (11.8) \frac{80 - 11}{80} = 10.2 \text{ p}$$

Because the crosswalk width is greater than 10 ft, the pedestrian service time is computed by using Equation 19-64.

$$t_{ps,co} = 3.2 + \frac{L_c}{S_p} + 2.7 \frac{N_{ped,co}}{W_c}$$

$$t_{ps,co} = 3.2 + \frac{28}{4.0} + (2.7) \frac{10.2}{16} = 11.9 \text{ s}$$

The other travel direction in the crosswalk is analyzed next. The number of pedestrians arriving at Corner 1 each cycle by crossing the minor street is computed by using Equation 19-68.

$$N_{ci} = \frac{v_{ci}}{3,600} C$$

$$N_{ci} = \frac{490}{3,600} (80) = 10.9 \text{ p}$$

The sequence of calculations is repeated for this second travel direction in the subject crosswalk to indicate that $N_{ped,ci}$ is equal to 9.4 p and $t_{ps,ci}$ is 11.8.

E. Compute Crosswalk Occupancy Time

The crosswalk occupancy time for the crosswalk is computed by using Equation 19-67.

$$T_{occ} = t_{ps,co} N_{co} + t_{ps,ci} N_{ci}$$

$$T_{occ} = 11.9(11.8) + 11.8(10.9) = 268.6 \text{ p-s}$$

F. Compute Pedestrian Crosswalk Circulation Area

Finally, the crosswalk circulation area per pedestrian for the crosswalk is computed by using Equation 19-69.

$$M_{cw} = \frac{TS_{cw}^*}{T_{occ}}$$

$$M_{cw} = \frac{3,790}{268.6} = 14.1 \text{ ft}^2/\text{p}$$

The crosswalk circulation area is found to be 14.1 ft²/p. According to the qualitative descriptions provided in Exhibit 19-28, pedestrians will find their walking speed is restricted, with very limited ability to pass slower pedestrians. Improvements to the crosswalk should be considered and may include a wider crosswalk or a longer walk interval.

Step 3: Determine Pedestrian Delay

The pedestrian delay is calculated by using Equation 19-70.

$$d_p = \frac{(C - g_{Walk,mj})^2}{2C}$$

$$d_p = \frac{(80 - 11)^2}{2(80)} = 29.8 \text{ s/p}$$

Step 4: Determine Pedestrian LOS Score for Intersection

The number of vehicles traveling on the minor street during a 15-min period is computed by using Equation 19-76.

$$n_{15,mi} = \frac{0.25}{N_c} \sum v_i$$

$$n_{15,mi} = \frac{0.25}{2} (72 + 336 + 60 + 42 + 400 + 76) = 123.3 \text{ veh/ln}$$

The cross-section adjustment factor is calculated by using Equation 19-72.

$$F_w = 0.681(N_c)^{0.514}$$

$$F_w = 0.681(2)^{0.514} = 0.972$$

The motorized vehicle adjustment factor is computed with Equation 19-73.

$$F_v = 0.00569 \left(\frac{v_{rtor} + v_{lt,perm}}{4} \right) - N_{rtci,c} (0.0027n_{15,mi} - 0.1946)$$

$$F_v = 0.00569 \left(\frac{30 + 42}{4} \right) - (0)(0.0027(123.3) - 0.1946) = 0.102$$

The motorized vehicle speed adjustment factor is then computed with Equation 19-74.

$$F_s = 0.00013 n_{15,mi} S_{85,mi}$$

$$F_s = 0.00013(123.3)(35) = 0.561$$

The pedestrian delay adjustment factor is calculated with Equation 19-75.

$$F_{delay} = 0.0401 \ln(d_{p,c})$$

$$F_{delay} = 0.0401 \ln(29.8) = 0.136$$

The pedestrian LOS score for the intersection $I_{p,int}$ is then computed with Equation 19-71.

$$I_{p,int} = 0.5997 + F_w + F_v + F_s + F_{delay}$$

$$I_{p,int} = 0.5997 + 0.972 + 0.102 + 0.561 + 0.136 = 2.37$$

Step 5: Determine LOS

According to Exhibit 19-9, the crosswalk operates at LOS B.

Discussion

The crosswalk was found to operate at LOS B in Step 5. It was determined in Step 1 that the pedestrians at both corners have adequate space to allow freedom of movement. However, crosswalk circulation area was found to be restricted in Step 2 and improvements are probably justified. Moreover, the pedestrian delay computed in Step 3 was found to be slightly less than 30 s/p. With this much delay, some pedestrians may not comply with the signal indication.

EXAMPLE PROBLEM 3: BICYCLE LOS

The Intersection

A 5-ft-wide bicycle lane is provided at a signalized intersection.

The Question

What is the LOS of this bicycle lane?

The Facts

- Saturation flow rate for bicycles = 2,000 bicycles/h
- Effective green time = 48 s
- Cycle length = 120 s
- Bicycle flow rate = 120 bicycles/h
- No on-street parking

The vehicular flow rates and street cross-section element widths are as shown in Exhibit 31-82.

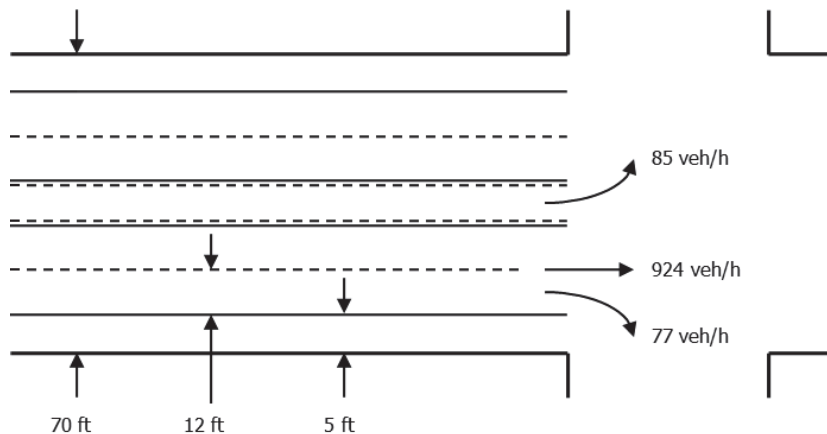

Exhibit 31-82
Example Problem 3: Vehicular Demand Flow Rates and Cross-Section Element Widths

Outline of Solution

Bicycle delay and the bicycle LOS score are computed. LOS is then determined on the basis of the computed score and the threshold values in Exhibit 19-9.

Computational Steps

The solution follows the steps listed in Exhibit 19-35 of Chapter 19.

Step 1: Determine Bicycle Delay

A. Compute Bicycle Lane Capacity

The capacity of the bicycle lane is calculated with Equation 19-77.

$$c_b = s_b \frac{g_b}{C}$$

$$c_b = (2,000) \frac{48}{120} = 800 \text{ bicycles/h}$$

B. Compute Bicycle Delay

Bicycle delay is computed with Equation 19-78.

$$d_b = \frac{0.5 C (1 - g_b/C)^2}{1 - \min\left(\frac{v_{bic}}{c_b}, 1.0\right) \frac{g_b}{C}}$$

$$d_b = \frac{0.5(120)(1 - 48/120)^2}{1 - \min\left(\frac{120}{800}, 1.0\right) \times \frac{48}{120}} = 23.0 \text{ s/bicycle}$$

Step 2: Determine Bicycle LOS Score for Intersection

As shown in Exhibit 31-82, the total width of the outside through lane, bicycle lane, and paved shoulder W_t is 17 ft (= 12 + 5 + 0 + 0). There is no on-street parking. The cross-section adjustment factor can then be calculated with Equation 19-80.

$$F_w = 0.0153 W_{cd} - 0.2144 W_t$$

$$F_w = 0.0153(70) - 0.2144(17) = -2.57$$

The motor-vehicle volume adjustment factor must be calculated by using Equation 19-81.

$$F_v = 0.0066 \frac{v_{lt} + v_{th} + v_{rt}}{4 N_{th}}$$

$$F_v = 0.0066 \frac{85 + 924 + 77}{4(2)} = 0.90$$

The bicycle LOS score can then be computed with Equation 19-79.

$$I_{b,int} = 4.1324 + F_w + F_v$$

$$I_{b,int} = 4.1324 - 2.57 + 0.90 = 2.45$$

Step 3: Determine LOS

According to Exhibit 19-9, the bicycle lane will operate at LOS B through the signalized intersection.

Discussion

The bicycle lane was found to operate at LOS B. The bicycle delay was found to be 23.0 s/bicycle, which is low enough that most bicyclists are not likely to be impatient. However, if the signal timing at the intersection were to be changed, the bicycle delay would need to be computed again to verify that it does not rise above 30 s/bicycle.



Many of these references are available in the Technical Reference Library in Volume 4.

10. REFERENCES

1. Zegeer, C., K. Opiela, and M. Cynecki. *Pedestrian Signalization Alternatives*. Report FHWA/RD-83/102. Federal Highway Administration, Washington, D.C., 1983.
2. Lieberman, E. B. Determining the Lateral Deployment of Traffic on an Approach to an Intersection. In *Transportation Research Record 772*, Transportation Research Board, National Research Council, Washington, D.C., 1980, pp. 1–5.
3. Bonneson, J. Lane Volume and Saturation Flow Rate for a Multilane Intersection Approach. *Journal of Transportation Engineering*, Vol. 124, No. 3, 1998, pp. 240–246.
4. Bonneson, J. A., and P. T. McCoy. *NCHRP Report 395: Capacity and Operational Effects of Midblock Left-Turn Lanes*. Transportation Research Board, National Research Council, Washington, D.C., 1997.
5. Teply, S. Accuracy of Delay Surveys at Signalized Intersections. In *Transportation Research Record 1225*, Transportation Research Board, National Research Council, Washington, D.C., 1989, pp. 24–32.
6. *Transportation Research Circular 212: Interim Materials on Highway Capacity*. Transportation Research Board, National Research Council, Washington, D.C., 1980.
7. Pline, J. L. (ed.). *Traffic Engineering Handbook*, 5th ed. ITE, Washington, D.C., 1999.
8. Reilly, W. R., and C. C. Gardner. Technique for Measuring Delay at Intersections. In *Transportation Research Record 644*, Transportation Research Board, National Research Council, Washington, D.C., 1977, pp. 1–7.
9. Powell, J. L. Field Measurement of Signalized Intersection Delay for 1997 Update of the *Highway Capacity Manual*. In *Transportation Research Record 1646*, Transportation Research Board, National Research Council, Washington, D.C., 1998, pp. 79–86.